

I manuali di officina sono stati realizzati da Moto Guzzi spa e gestioni precedenti, gli stessi NON sono coperti da copyright.

Alcune persone dopo aver comodamente scaricato dal nostro sito internet i manuali li rivendevano a caro prezzo ad acquirenti ignari del fatto che tale documentazione tecnica, è consultabile e scaricabile all'indirizzo internet

<http://www.officina.moto-guzzi.it>

GRATUITAMENTE

A tutela dei consumatori

L'associazione culturale Moto-Guzzi.it ritiene utile avvisare che:

*"Questo materiale è messo a disposizione di tutti **GRATUITAMENTE** sul sito www.moto-guzzi.it non è pertanto utilizzabile a scopi commerciali. Segnalateci eventuali abusi all'indirizzo e-mail: info@motoguzzi.it*

e a salvaguardia del lavoro di compiuto dal curatore della sezione tecnica e delle spese di hosting sostenute dalla Associazione culturale Moto-Guzzi.it il proprio logo.



MOTO GUZZI
250 TS
Max. cilindrata: 250 cc
Velocità: 100 km/h
Raffreddo: a liquido
Consumo: 20 km/l
Prezzo: 18.000.000

MOTO GUZZI

MOTO GUZZI

Mo

MOTO GUZZI

MOTO GUZZI
cos
pre
ndita

Cette parts list est issue de la numérisation d'un document papier original Moto Guzzi.

Ce document dispose de "signets" permettant de naviguer plus rapidement au sein de la parts list.

Merci de communiquer toute information à Sergio : california@free.fr

La liste de discussion/diffusion sur laquelle le lecteur est convié est : <http://fr.groups.yahoo.com/group/guzzitek>

N'oubliez pas de visiter le site historique le plus complet de Moto Guzzi : <http://perso.wanadoo.fr/rolcat.vm/guzzi>

Merci à tous ceux qui contribuent à la Guzzithèque.

Document édité le 31 août 2003

This Parts List is a scanned original paper document from Moto Guzzi.

The document as bookmarks for easier navigation.

Please any comment to Sergio : california@free.fr

Don't forget to visit the best historical web site about Moto Guzzi : <http://perso.wanadoo.fr/rolcat.vm/guzzi>

Thanks to all the friends that contribute to the "Guzzithèque".

Issued August 2003, the 31.

MOTO-GUZZI.IT
 ASSOCIAZIONE

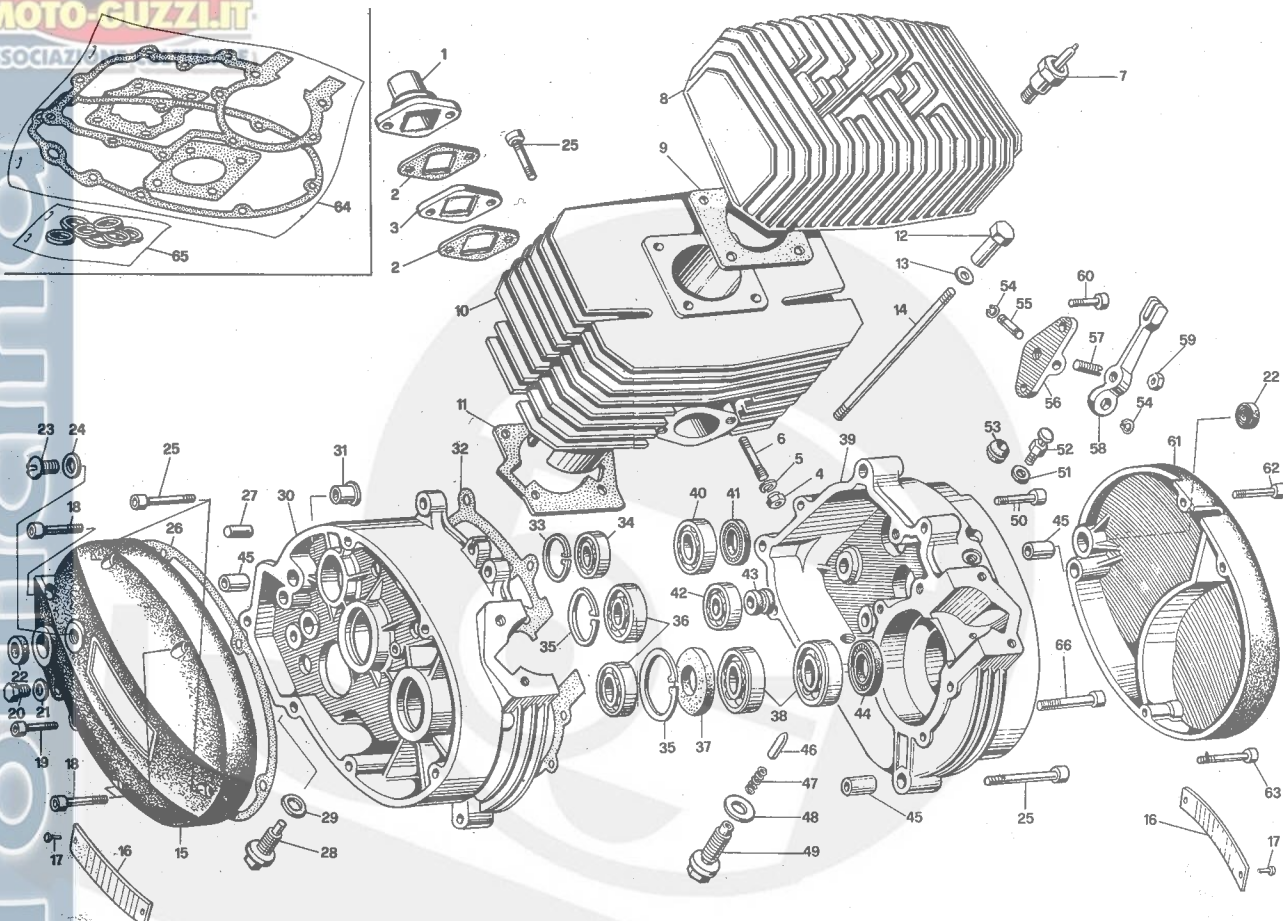

NOTE NOTES NOTES MARKE	POS. N.	N. COD. CODE No. No. CODE CODE Nr.	DENOMINAZIONE	DESCRIPTION	DESIGNATION	BEZEICHNUNG	N. DIS. DRWG. No. No. PLAN ZEICHN. Nr.
	1	39 11 50 00	Collettore aspirazione	Manifold	Collecteur d'admission	Ansaugkrümmer	
	2	39 11 55 00	Guarnizione	Gasket	Joint	Dichtung	
	3	35 11 51 71	Distanziale	Spacer	Entretoise	Distanzstück	
	4	92 75 00 85	Dado	Nut	Ecrou	Mutter	
	5	61 27 03 00	Rosetta ondulata	Washer	Rondelle	Unterlegscheibe	
	6	35 02 05 70	Prigioniero	Stud bolt	Goujon prisonnier	Stiftschraube	
	7	25 71 70 25	Candela di accensione	Spark plug	Bougie d'allumage	Zündkerze	
	8	35 02 24 70	Testa motore	Cylinder head	Culasse	Zylinderkopf	
	9	39 02 20 00	Guarnizione	Gasket	Joint	Dichtung	
	10	35 02 03 71	Cilindro	Cylinder	Cylindre	Zylinder	
	11	39 02 08 00	Guarnizione	Gasket	Joint	Dichtung	
	12	39 02 19 00	Dado fiss. testa	Nut	Ecrou	Mutter	
	13	95 10 04 16	Rosetta piana	Washer	Rondelle	Unterlegscheibe	
	14	39 02 17 00	Prigioniero	Stud bolt	Goujon prisonnier	Stiftschraube	
	15	35 00 16 70	Coperchio destro	R.H. cover	Couvercle D	Deckel, R.	
	16	35 01 55 00	Targh. motore "Guzzi"	"Guzzi" engine badge	Plaque mot. "Guzzi"	Motorschild "Guzzi"	
	16	62 00 98 01	Targh. mot. "Benelli"	"Benelli" eng. badge	Plaque mot. "Benelli"	Motorschild "Benelli"	
	17	91 80 02 03	Chiodino autofilett.	Rivet	Rivet	Nagel	
	18	98 62 03 35	Vite	Screw	Vis	Schraube	
	19	98 62 03 25	Vite	Screw	Vis	Schraube	
	20	98 05 43 10	Bullone	Bolt	Boulon	Bolzen	
	21	90 71 40 62	Guarnizione	Gasket	Joint	Dichtung	
	22	90 40 15 25	Anello di tenuta	Seal ring	Bague d'étanchéité	Dichtring	
	23	35 01 88 00	Tappo carico olio	Filling plug	Bouchon de rempl. h.	Füllungpfropfen	
	24	90 71 41 52	Guarnizione	Gasket	Joint	Dichtung	
	25	98 62 03 30	Vite	Screw	Vis	Schraube	
	26	35 00 12 00	Guarnizione	Gasket	Joint	Dichtung	
	27	35 01 10 00	Picchetto riscontro	Dowel	Cliquet	Zapfen	
	28	35 26 59 00	Bullone	Bolt	Boulon	Bolzen	
	29	90 71 41 27	Guarnizione	Gasket	Joint	Dichtung	
	30	35 00 11 70	Carter destro	Right crankcase	Carter droit	Rechts Gehäuse	
	31	35 01 70 00	Boccola	Bush	Douille	Buchse	
	32	35 00 09 70	Guarnizione	Gasket	Joint	Dichtung	
	33	90 27 20 32	Anello di sicurezza	Circlip	Bague d'arrêt	Sicherheitsring	
	34	92 20 12 11	Cuscinetto	Bearing	Roulement	Kugellager	
	35	90 27 20 40	Anello di sicurezza	Circlip	Bague d'arrêt	Sicherheitsring	
	36	92 20 12 18	Cuscinetto	Bearing	Roulement	Kugellager	

MOTO-SUZZIT
ASSOCIATI

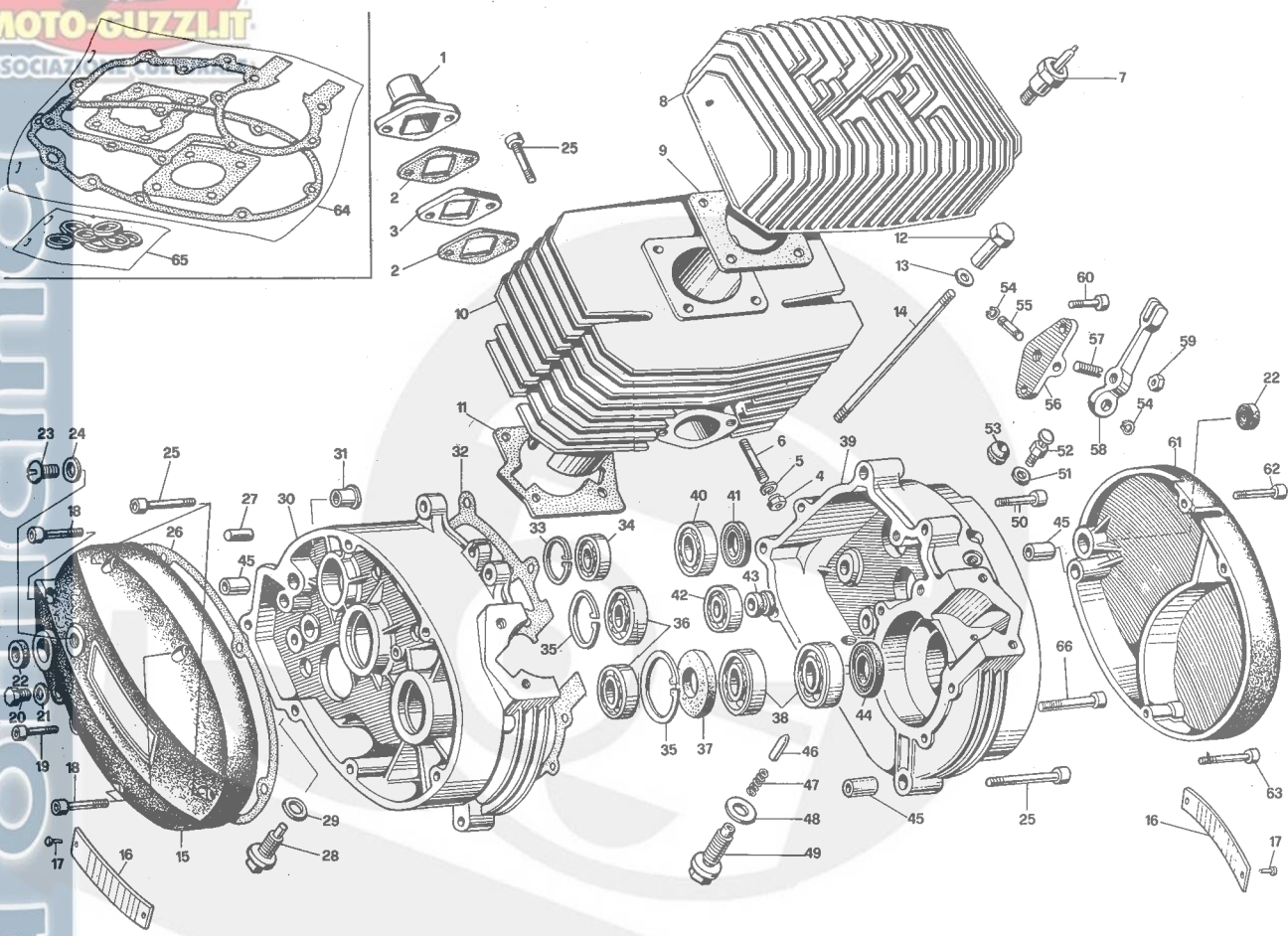

NOTE NOTES NOTES MARKE	POS. N.	N. COD. CODE No. No. CODE CODE Nr.	DENOMINAZIONE	DESCRIPTION	DESIGNATION	BEZEICHNUNG	N. DIS. DRWG. No. No. PLAN ZEICHN. Nr.
	37	90 40 17 43	Anello di tenuta	Seal ring	Bague d'étanchéité	Dichtring	
	38	92 20 12 19	Cuscinetto	Bearing	Roulement	Kugellager	
	39	35 00 08 70	Carter sinistro	Left crankcase	Carter gauche	Links Gehäuse	
	40	92 20 14 16	Cuscinetto	Bearing	Roulement	Kugellager	
	41	90 40 15 31	Anello di tenuta	Seal ring	Bague d'étanchéité	Dichtring	
	42	92 20 12 16	Cuscinetto	Bearing	Roulement	Kugellager	
	43	91 55 10 73	Anello di tenuta	Seal ring	Bague d'étanchéité	Dichtring	
	44	90 40 20 35	Anello di tenuta	Seal ring	Bague d'étanchéité	Dichtring	
	45	35 00 20 00	Picchetto di riferimento	Dowel	Cliquet	Zapfen	
	46	39 01 10 00	Picchetto arresto marce	Dowel	Cliquet	Zapfen	
	47	35 01 11 00	Molla	Spring	Ressort	Feder	
	48	10 15 42 00	Guarnizione	Gasket	Joint	Dichtung	
	49	39 01 12 00	Bullone porta picc.	Bolt	Boulon	Bolzen	
	50	98 62 03 55	Vite	Screw	Vis	Schraube	
	51	90 71 40 80	Guarnizione	Gasket	Joint	Dichtung	
	52	48 00 46 70	Sfioratore	Spillway	Déservoir	Überlauf	
	53	91 55 10 70	Cappellotto usc. cavi	Cap	Capuchon	Deckel	
	54	90 27 10 03	Anello di sicurezza	Circlip	Bague d'arrête	Sicherheitsring	
	55	35 09 07 00	Spina fulcro leva	Pin	Clavette	Zapfen	
	56	35 09 09 00	Supporto leva	Support	Support levier	Halterung	
	57	39 09 04 00	Vite reg. frizione	Clutch screw	Vis embrayage	Kupplungsschraube	
	58	35 09 02 00	Leva frizione	Clutch lever	Levier d'embrayage	Kupplungshebel	
	59	92 60 24 06	Dado	Nut	Ecrou	Mutter	
	60	98 62 23 16	Vite	Screw	Vis	Schraube	
	61	35 00 04 00	Coperchio sinistro	Left cover	Couvercle gauche	Links Deckel	
	62	98 62 23 20	Vite	Screw	Vis	Schraube	
	63	98 62 03 40	Vite	Screw	Vis	Schraube	
	64	35 99 90 71	Serie guarnizioni	Gasket set	Série joints	Dichtungreihe	
	65	35 99 95 71	Serie paraoli	Oil seal set	Série de pare-huile	Dichtungssatz	
	66	98 62 03 70	Vite	Screw	Vis	Schraube	
		35 00 01 70	Carter accoppiati	Coupled carter	Carter jumelé	Motorgehäuse	

MOTO-GUZZI.IT
 ASSOCIAZIONE CULTURALE

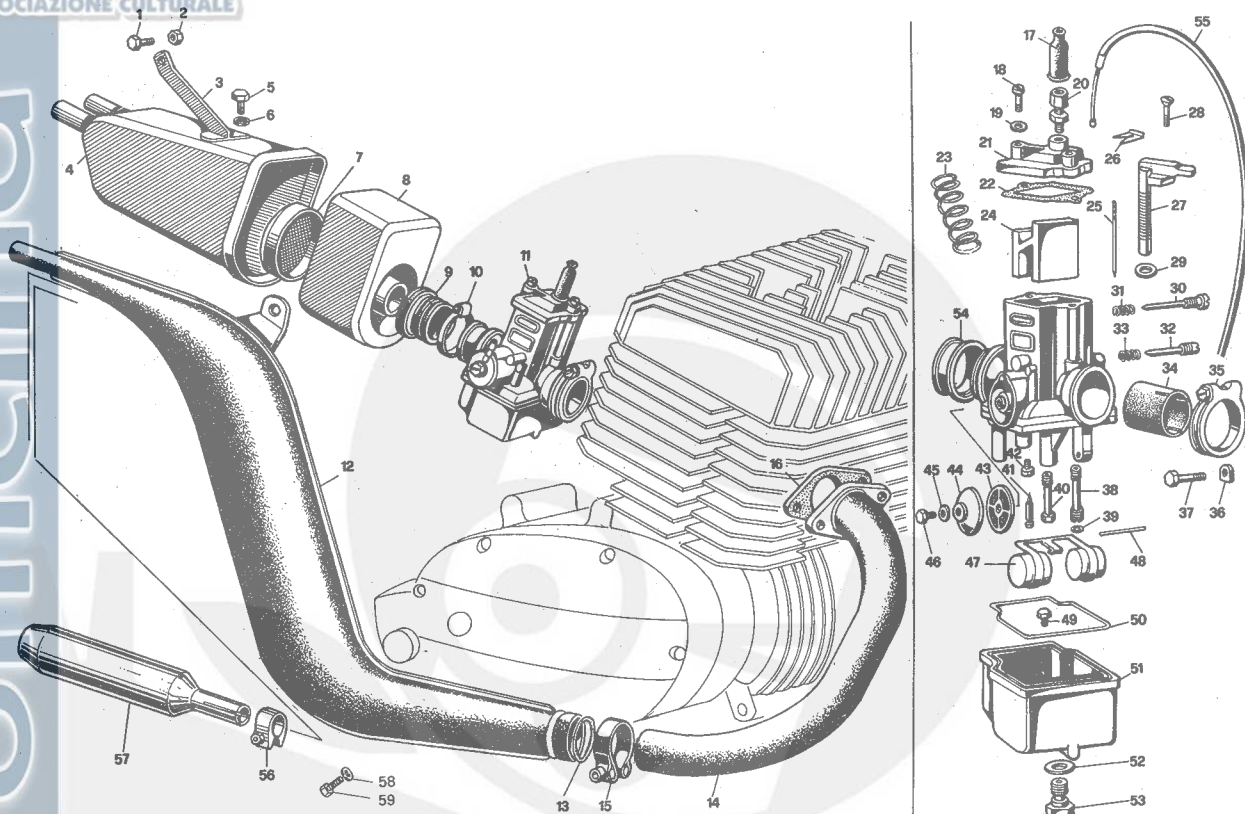

NOTE NOTES NOTES MARKE	POS. N.	N. COD. CODE No. No. CODE CODE Nr.	DENOMINAZIONE	DESCRIPTION	DESIGNATION	BEZEICHNUNG	N. DIS. DRWG. No. No. PLAN ZEICHN. Nr.
	1	98 05 43 14	Bullone	Bolt	Boulon	Bolzen	
	2	92 60 22 06	Dado	Nut	Ecrou	Mutter	
	3	35 11 64 70	Staffa sost. silenz. asp.	Bracket	Etrier	Bügel	
	4	35 11 61 71	Silenziatore asp. post.	Rear int. muffler	Silenc. aspir. arrière	Hint. Ansaugungschalldäm.	
	5	98 05 43 14	Bullone	Bolt	Boulon	Bolzen	
	6	95 00 02 06	Rosetta piana	Washer	Rondelle	Unterlegscheibe	
	7	35 11 36 70	Filtro aria	Air filter	Filtre air	Luftfilter	
	8	35 11 04 70	Silenziatore asp. anter.	Front int. muffler	Silenc. aspir. avant	Vord. Ausaugungschalldäm.	
	9	61 11 44 00	Manicotto	Sleeve	Manchon	Manschette	
	10	93 30 50 25	Fascetta	Clamp	Collier	Schelle	
	11	35 11 26 71	Carburatore	Carburetor	Carburateur	Vergaser	
	12	35 12 30 71	Silenziatore scarico	Exhaust muffler	Silenc. échappem.	Auspuffschalldäm.	
	13	39 12 67 00	Anello di tenuta	Seal ring	Bague d'étanchéité	Dichtring	
	14	35 12 07 71	Tubo scarico	Exhaust pipe	Tuyau d'échappem.	Auspuffrohr	
	15	35 12 70 70	Fascetta tubo scar.	Exhaust pipe clamp	Collier tuyau d'éch.	Auspuffrohrschelle	
	16	39 12 03 00	Guarnizione	Gasket	Joint	Dichtung	
	17	13 93 70 00	Cappuccio	Cover	Couvercle	Deckel	
	18	13 93 28 00	Vite	Screw	Vis	Schraube	
	19	13 93 21 00	Rosetta	Washer	Rondelle	Unterlegscheibe	
	20	49 93 87 00	Vite tendifilo	Screw	Vis	Schraube	
	21	53 93 50 00	Coperchio valvola	Cover	Couvercle	Deckel	
	22	35 93 22 70	Guarnizione	Gasket	Joint	Dichtung	
	23	13 93 71 00	Molla	Spring	Ressort	Feder	
	24	35 93 75 70	Valvola gas	Gas valve	Soupape de gaz	Gasventil	
	25	35 93 77 71	Spillo conico	Needle	Pointeau conique.	Kon. Nadel	
	26	55 93 85 85	Fermaglio	Fastener clip	Goujon	Klemme	
	27	35 93 78 70	Dispositivo avviam.	Starter device	Dispositif de démarr.	Startvorrichtung	
	28	13 93 79 00	Vite	Screw	Vis	Schraube	
	29	14 93 83 00	Guarnizione	Gasket	Joint	Dichtung	
	30	13 93 66 00	Vite	Screw	Vis	Schraube	
	31	13 93 67 00	Molla	Spring	Ressort	Feder	
	32	13 93 62 00	Vite	Screw	Vis	Schraube	
	33	13 93 63 00	Molla	Spring	Ressort	Feder	
	34	39 93 89 00	Riduzione isolante	Bush	Réduction isolante	Buchse	
	35	39 93 87 00	Fascetta	Clamp	Collier	Schelle	
	36	14 93 68 00	Dado	Nut	Ecrou	Mutter	

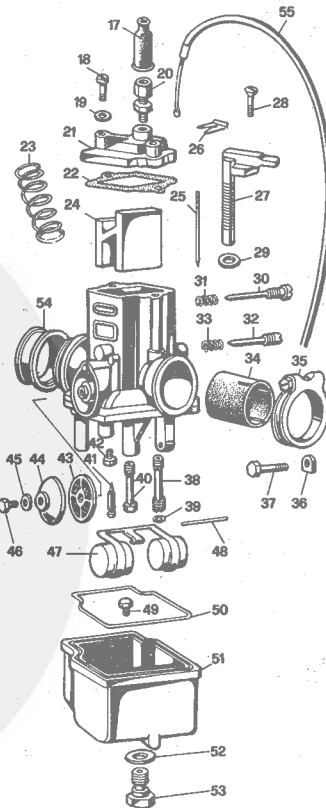
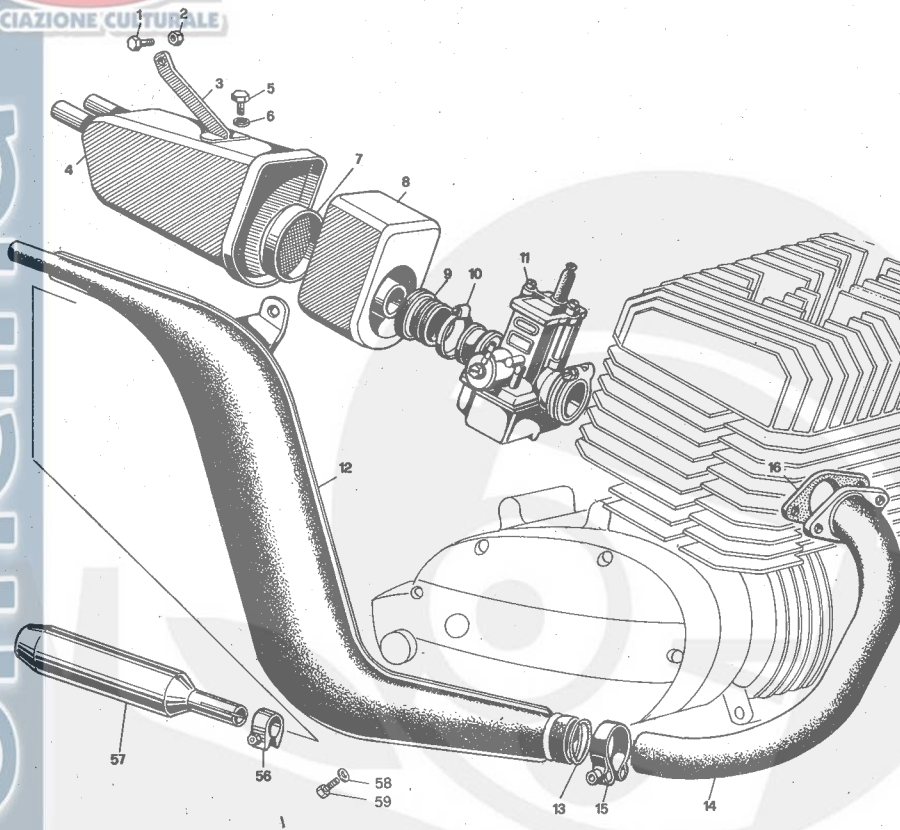

NOTE NOTES NOTES MARKE	POS. N.	N. COD. CODE No. No. CODE CODE Nr.	DENOMINAZIONE	DESCRIPTION	DÉSIGNATION	BEZEICHNUNG	N. DIS. DRWG. No. No. PLAN ZEICHN. Nr.
	37	14 93 86 00	Vite	Screw	Vis	Schraube	
	38	53 93 60 00	Getto-avviamento	Starting jet	Gicleur démarrage	Anlassvergassung	
	39	13 93 61 00	Guarnizione	Gasket	Joint	Dichtung	
	40	39 93 55 00	Polverizzatore	Fuel nozzle	Pulvérisateur	Einspritzdüse	
	41	13 93 48 00	Spillo chiuso benzina	Fuel needle	Pointeau d'essence	Benzinnadel	
	42	35 93 59 70	Getto minimo	Slow running jet	Gicleur ralenti	Minid. Vergassung	
	43	43 93 40 00	Filtro	Filter	Filtre	Filter	
	44	35 93 46 70	Pipetta	Union	Tuyau de raccord	Pipette	
	45	13 93 47 00	Guarnizione	Gasket	Joint	Dichtung	
	46	13 93 49 00	Vite	Screw	Vis	Schraube	
	47	14 93 30 00	Galleggiante	Float	Flotteur	Schwimmer	
	48	13 93 31 00	Perno	Pin	Pivot	Stift	
	49	35 93 57 71	Getto massimo	Main jet	Gicleur principal	Max. Vergassung	
	50	13 93 34 00	Guarnizione	Gasket	Joint	Dichtung	
	51	53 93 44 00	Corpo vaschetta	Chamber body	Corps cuvette	Beckengehäuse	
	52	53 93 39 00	Guarnizione	Gasket	Joint	Dichtung	
	53	53 93 37 00	Tappo vaschetta	Chamber plug	Bouchon cuvette	Beckenzapfen	
	54	39 11 44 00	Raccordo	Union	Raccord	Rohrverschraubung	
	55	35 11 75 70	Filo com. gas	Gas cable	Cable comm. gaz	Gaszug	
	56	35 12 94 70	Fascetta per codino	Clamp	Collier	Schelle	
	57	35 12 77 70	Codino per silenz.	Tail pipe	Tuyau	Auspuffenstück	
	58	95 10 01 16	Guarnizione	Gasket	Joint	Dichtung	
	59	98 05 43 08	Vite	Screw	Vis	Schraube	

MOTO-GUZZI
 ASSOCIAZIONE CULTURALE

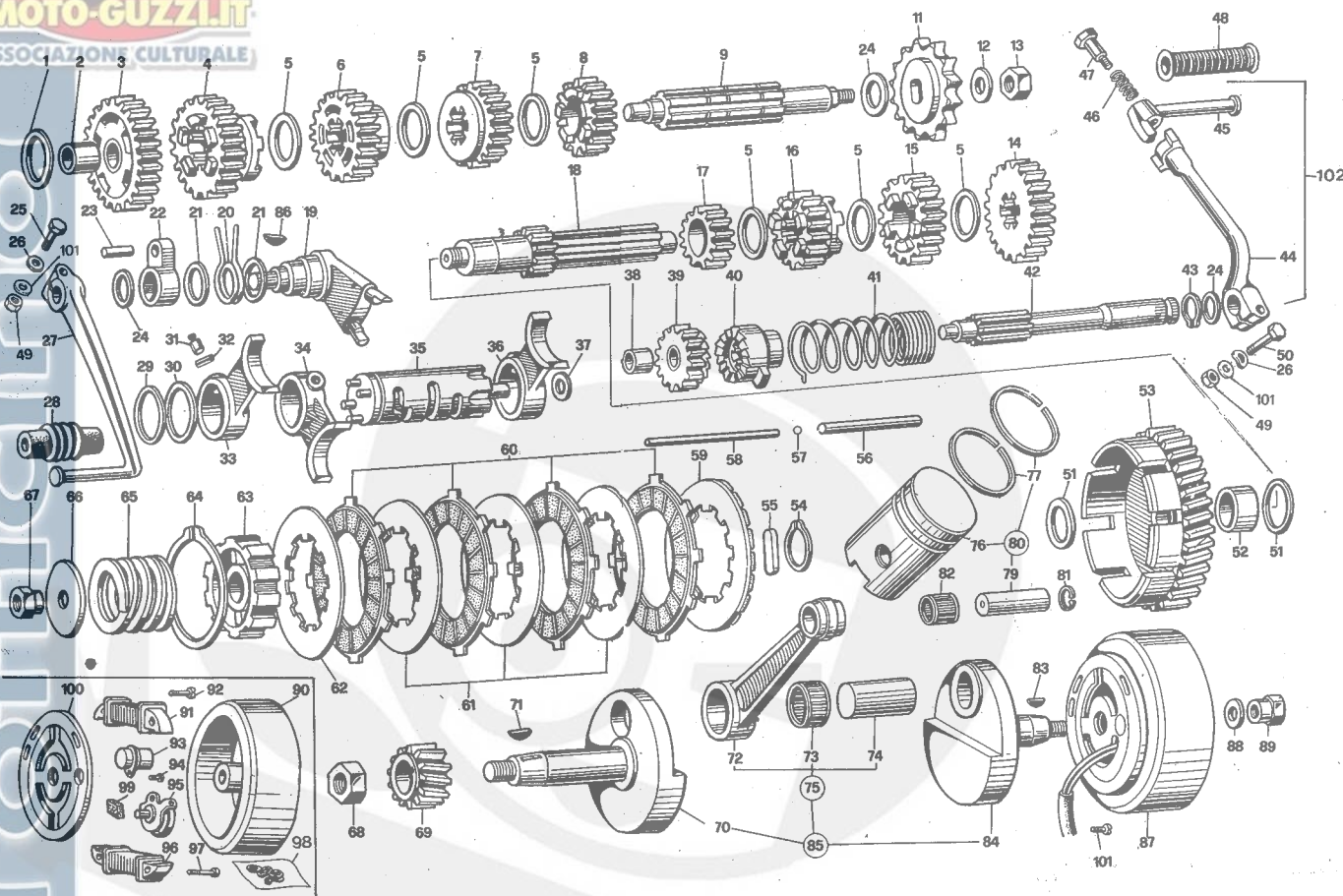

NOTE NOTES NOTES NOTES MARKE	POS. N.	N. COD. CODE No. No. CODE CODE Nr.	DENOMINAZIONE	DESCRIPTION	DESIGNATION	BEZEICHNUNG	N. DIS. DRWG. No. No. PLAN ZEICHN. Nr.
	74	35 06 50 00	Perno unione	Pin	Goujon	Stift	
	75	35 06 14 70	Biella completa	Connecting rod, assy	Bielle complète	Pleuel, kpl.	
	76	39 06 04 00	Pistone	Piston	Piston	Kolben	
	77	39 06 08 00	Anello elastico	Piston ring	Bague élastique	Kolbenring	
	79	39 06 12 00	Spinotto	Piston pin	Axe du piston	Kolbenbolzen	
	80	39 06 02 00	Pistone completo	Piston, compl.	Piston complet	Kolben, kpl.	
	81	90 35 30 18	Anello fermo spin.	Retaining ring	Bague de serrage	Verschlussring	
	82	92 25 20 15	Gabbia piede biella	Cage	Cage	Nadelkäfig	
	83	91 60 02 38	Linguetta americana	Woodruff key	Languette	Scheibenfeder	
	84	35 06 44 71	Volano sinistro	Left flywheel	Volant gauche	Links Schwungrad	
	85	35 06 40 71	Biellismo completo	Connect. rod, assy	Tringlerie complète	Pleuelwerk., kpl.	
	86	91 60 04 50	Linguetta americana	Woodruff key	Languette	Scheibenfeder	
	87	35 71 24 70	Volano magnete	Flywheel magneto	Volant de la magnéto	Magnetschwungrad	
	88	95 10 12 75	Rosetta	Washer	Rondelle	Unterlegscheibe	
	89	35 06 72 70	Dado	Nut	Ecrou	Mutter	
	90	35 71 16 70	Rotore volano	Flywheel rotor	Rotor à volant	Schwungradrotor	
	91	35 71 50 70	Bobina alimentazione	Coil	Bobine	Spule	
	92	35 71 56 70	Vite	Screw	Vis	Schraube	
	93	35 70 86 00	Condensatore	Condenser	Condensateur	Kondensator	
	94	35 70 79 00	Vite	Screw	Vis	Schraube	
	95	35 70 88 00	Ruttore completo	Contact break, compl.	Rupteur complet	Unterbrecker, kpl.	
	96	35 71 51 70	Bobina luce	Coil	Bobine	Lichtspule	
	97	35 71 56 00	Vite	Screw	Vis	Schraube	
	98	35 71 57 00	Bustina viti, rondelle	Screws & washers set	Envel, vis et rondelles	Schrauben, Unterleg. Satz	
	99	35 70 95 70	Ingrassatore	Lubricator	Graisser	Fettbüchse	
	100	35 70 22 00	Piastra statore	Plate	Plaque du stator	Ständerplatte	
	101	95 00 02 06	Rosetta piana	Washer	Rondelle	Unterlegscheibe	
	102	35 26 02 50	Pedale avv. compl.	Starter pedal, compl.	Péd. de mise en m. c.	Kickstarter, kpl.	

MOTO-GUZZI.IT
ASSOCIAZIONE CULTURALE

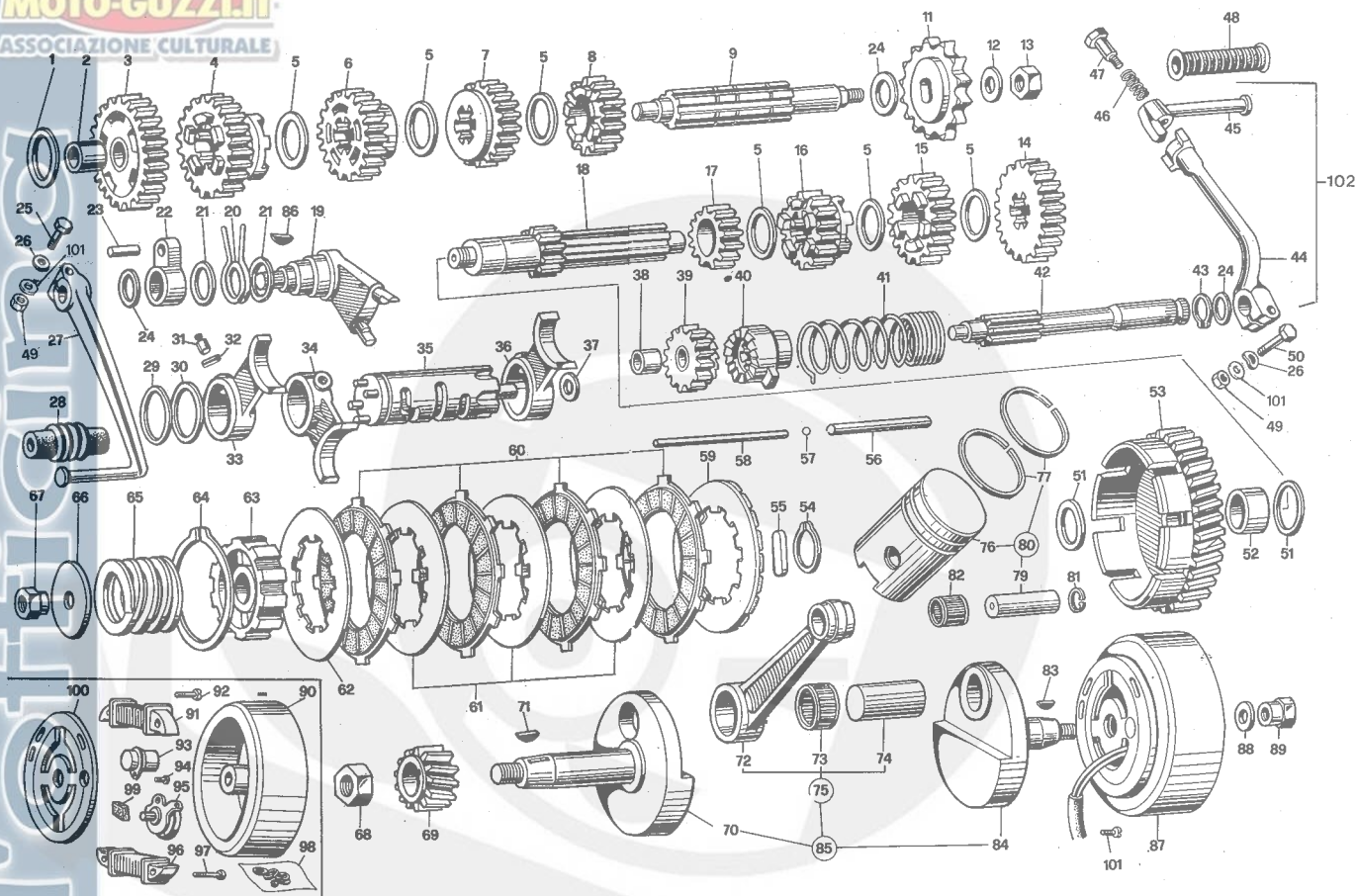

NOTE NOTES NOTES MARKE	POS. N.	N. COL. CODE No. No. CODE CODE Nr.	DENOMINAZIONE	DESCRIPTION	DESIGNATION	BEZEICHNUNG	N. DIS. DRWG. No. No. PLAN ZEICHN. Nr.
	38	35 26 67 00	Boccola	Bush	Douille	Buchse	
	39	35 26 64 00	Ingranaggio avviam.	Starter gear	Engrenage démarrage	Starterzahnrad	
	40	35 26 65 00	Bussola dentata	Bush	Douille	Buchse	
	41	35 26 62 00	Molla	Spring	Ressort	Feder	
	42	35 26 45 00	Albero avviamento	Starter shaft	Arbre de démarrage	Starterwelle	
	43	90 27 10 15	Anello di sicurezza	Circlip	Bague d'arrêt	Sicherheitsring	
	44	35 26 05 00	Pedale avviamento	Starter pedal	Pédale de mise en mar.	Kickstarter	
	45	35 26 25 00	Perno girevole	Pin	Pivot	Zapfen	
	46	35 26 24 00	Molla	Spring	Ressort	Feder	
	47	35 26 23 00	Bullone	Bolt	Boulon	Bolzen	
	48	35 26 21 00	Pedana ped. avviam.	Foot rest	Repose-pieds	Trittbrett	
	49	92 60 22 06	Dado	Nut	Ecrou	Mutter	
	50	98 05 23 35	Bullone	Bolt	Boulon	Bolzen	
	51	35 21 54 00	Rosetta rasamento	Washer	Rondelle	Unterlegscheibe	
	52	35 08 36 70	Boccola	Bush	Douille	Buchse	
	53	35 08 11 70	Ingranaggio frizione	Clutch gear	Engrenage de l'embr.	Kupplungsantrieb	
	54	90 27 10 17	Anello di sicurezza	Circlip	Bague d'arrêt	Sicherheitsring	
	55	35 08 54 00	Chiavetta	Key	Clavette	Keil	
	56	35 08 55 00	Astina lunga	Long rod	Tige longue	Langhebel	
	57	92 29 57 04	Sfera	Ball	Bille	Kugel	
	58	35 08 57 00	Astina corta	Short rod	Tige courte	Kurzhebel	
	59	35 08 21 00	Disco int. condotto	Ins. driven plate	Disque int. conduit	Treibscheibe	
	60	35 08 23 00	Disco conduttore	Driving plate	Disque conducteur	Leitungsscheibe	
	61	35 08 26 00	Disco condotto	Driven plate	Disque conduit	Treibscheibe	
	62	35 08 23 70	Disco eterno	Outside plate	Disque extérieur	Aüss. Kupplungscheibe	
	63	35 08 18 70	Tamburo portadischi	Disc holder drum	Tamb. porte-disques	Kupplungsscheibe Tr.	
	64	90 27 10 70	Anello di sicurezza	Circlip	Bague d'arrêt	Sicherheitsring	
	65	35 08 41 00	Molla	Spring	Ressort	Feder	
	66	35 08 38 00	Rosetta riscontro	Washer	Rondelle	Unterlegscheibe	
	67	35 06 72 00	Dado	Nut	Ecrou	Mutter	
	68	92 70 11 07	Dado	Nut	Ecrou	Mutter	
	69	35 07 02 70	Ingranaggio motore	Driving gear	Engrenage moteur	Motorzahnrad	
	70	35 06 43 71	Volano destro	Right flywheel	Volant droit	Rechts Schwungrad	
	71	91 60 03 37	Linguetta americana	Woodruff key	Langulette	Scheibenfeder	
	72	39 06 15 00	Biella	Connecting rod	Bielle	Pleuel	
	73	92 25 20 18	Gabbietta testa biella	Cage	Cage	Nadelkäfig	

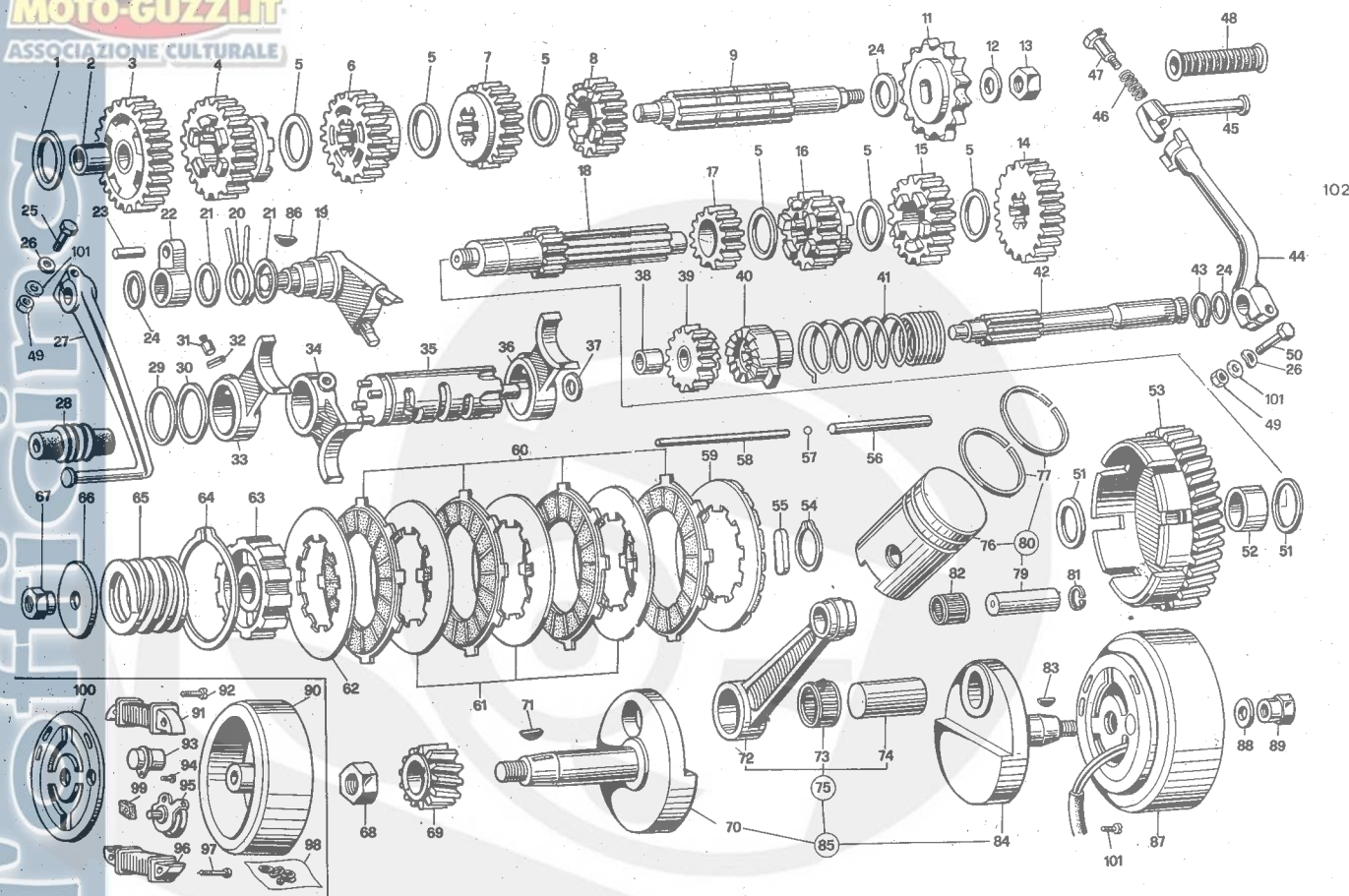

NOTE NOTES NOTES NOTES MARKE	POS. N.	N. COD. CODE No. No. CODE CODE Nr.	DENOMINAZIONE	DESCRIPTION	DESIGNATION	BEZEICHNUNG	N. DIS. DRWG. No. No. PLAN ZEICHN. Nr.
	1	35 21 38 00	Rosetta arr. ingr.	Washer	Rondelle	Unterlegscheibe	
	2	35 21 41 00	Boccola	Bush	Douille	Büchse	
	3	35 21 42 70	Ingran. 1a A.S.	1st speed gear S.S.	Pignon 1ère vit. A.I.	Zahnrad 1. Gang-Stw.	
	4	35 21 45 00	Ingran. 2a A.S.	2nd speed gear S.S.	Pignon 2ème vit. A.I.	Zahnrad 2. Gang-Stw.	
	5	35 21 55 00	Anello fermo ingran.	Retaining ring	Bague de serrage	Verschlussring	
	6	35 21 48 00	Ingran. 3a A.S.	3rd speed gear S.S.	Pignon 3ème vit. A.I.	Zahnrad 3. Gang-Stw.	
	7	35 21 51 00	Ingran. 4a A.S.	4th speed gear S.S.	Pignon 4ème vit. A.I.	Zahnrad 4. Gang-Stw.	
	8	35 21 52 00	Ingran. 5a A.S.	5th speed gear S.S.	Pignon 5ème vit. A.I.	Zahnrad 5. Gang-Stw.	
	9	35 21 36 00	Albero secondario	Secondary shaft	Arbre intermédiaire	Steuerwelle	
	11	35 33 05 71	Ingran. rinvio cambio	Transmission gear	Engrenage boîte à vit.	Schalttriebeantrieb	
	12	95 00 02 13	Rosetta	Washer	Rondelle	Unterlegscheibe	
	13	92 60 25 12	Dado	Nut	Ecrou	Mutter	
	14	35 21 20 00	Ingran. 5a A.P.	5th speed gear O.S.	Pignon 5ème vit. A.P.	Zahnrad 5. Gang-Hptw.	
	15	35 21 18 00	Ingran. 4a A.P.	4th speed gear O.S.	Pignon 4ème vit. A.P.	Zahnrad 4. Gang-Hptw.	
	16	35 21 14 00	Ingran. 3a A.P.	3rd speed gear O.S.	Pignon 3ème vit. A.P.	Zahnrad 3. Gang-Hptw.	
	17	35 21 13 00	Ingran. 2a A.P.	2nd speed gear O.S.	Pignon 2ème vit. A.P.	Zahnrad 2. Gang-Hptw.	
	18	35 21 06 00	Albero primario	Out-put shaft	Arbre primaire	Hauptwelle	
	19	35 23 62 00	Corpo preselett. comp.	Preselector body assy	Corps présélec. comp.	Verwählerkast. - kpl.	
	20	35 25 12 00	Molla	Spring	Ressort	Feder	
	21	35 25 29 00	Rosetta riscontro	Washer	Rondelle	Unterlegscheibe	
	22	35 23 79 00	Nasello	Nib	Déclic	Nase	
	23	35 23 77 00	Picchetto nasello	Nib peg	Piquet déclit	Nasestift	
	24	35 23 81 00	Rosetta	Washer	Rondelle	Unterlegscheibe	
	25	98 05 23 30	Bullone	Bolt	Boulon	Bolzen	
	26	61 01 38 00	Rosetta ondulata	Washer	Rondelle	Unterlegscheibe	
	27	35 25 09 00	Pedana cambio	Transmission pedal	Pédale boîte à vit.	Schalttriebe pedal	
	28	39 25 10 00	Pedana pedale cambio	Foot rest	Repose-pieds	Trittbrett	
	29	35 23 50 00	Rosetta riscontro	Washer	Rondelle	Unterlegscheibe	
	30	35 23 86 00	Anello fermo albero	Retaining ring	Bague de serrage	Verschlussring	
	31	35 23 87 01	Grano di guida	Dowel	Grain	Stift	
	32	95 52 02 12	Rosetta di fermo	Washer	Rondelle	Unterlegscheibe	
	33	35 23 05 70	Forc. ingran. 2a A.S.	2nd gear S.S. fork	Four. engr. 2ème A.I.	Schaltgab. Zahnr. 2. Gang-Stw.	
	34	35 23 08 70	Forc. ingran. 3a A.P.	3rd gear O.S. fork	Four. engr. 3ème A.P.	Schaltgab. Zahnr. 3. Gang-Hptw.	
	35	35 23 45 00	Albero desmodromico	Splined shaft	Arbre desmodromique	Keilwelle	
	36	35 23 12 70	Forc. ingran. 4a A.S.	4th gear S.S. fork	Four. engr. 4ème A.I.	Schaltgab. Zahnr. 4. Gang-Stw.	

MOTO GUZZI.IT
ASSOCIAZIONE CULTURALE

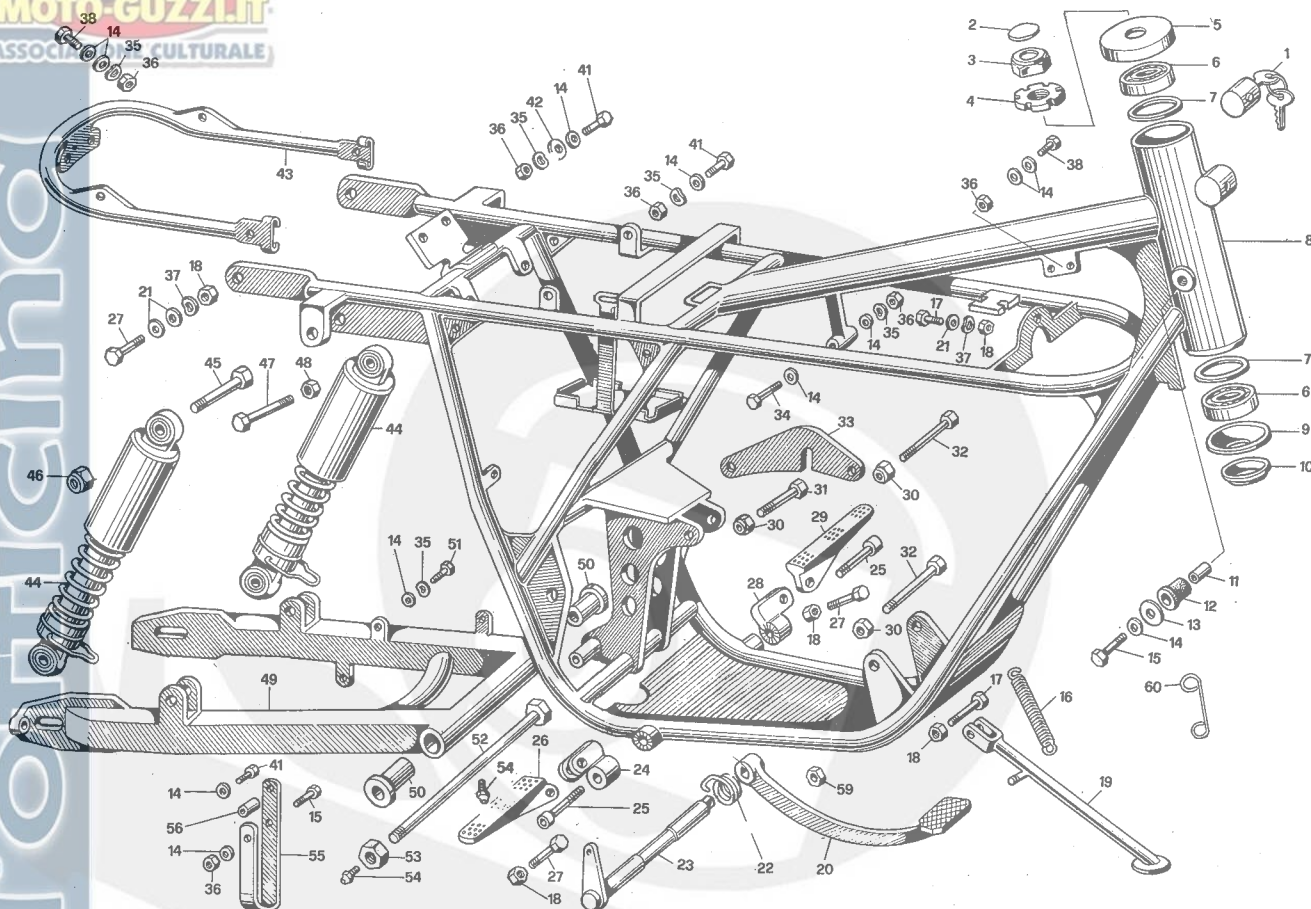

NOTE NOTES NOTES MARKE	POS. N.	N. COD. CODE No. No. CODE CODE Nr.	DENOMINAZIONE	DESCRIPTION	DESIGNATION	BEZEICHNUNG	N. DIS. DRWG. No. No. PLAN ZEICHN. Nr.
	1	35 78 25 70	Bloccasterzo	Antitheft	Blocage de col. de dir.	Lenkschloss	
	2	17 51 77 00	Marchio sterzo "Guzzi"	"Guzzi" steer. badge	Plaque col. dir. "Guzzi"	Lenkerstempel "Guzzi"	
	3	63 01 55 00	Marchio ster. "Benelli"	"Benelli" steer. badge	Pl. col. dir. "Benelli"	Lenkerstempel "Benelli"	
	4	35 51 33 70	Dado serr. sterzo	Steering locking nut	Ecrou serr. col. de dir.	Lenkklemmutter	
	5	35 49 45 70	Ghiera per sterzo	Ring nut	Embout	Lenkernutmutter	
	6	35 49 45 70	Copripolvere	Dust cover	Pare-poussière	Lenkungstaubschutz	
	7	92 24 92 26	Cuscinetto	Bearing	Roulement	Kugellager	
	8	35 49 49 70	Rosetta spallamento	Washer	Rondelle	Unterlegscheibe	
	9	35 40 01 70	Telaio completo	Frame, compl.	Châssis complet	Rahmen, kpl.	
	10	35 51 70 70	Gommino parapolvere	Rubber block	Caoutchouc	Gummistück	
	11	35 10 35 70	Tubetto	Tube	Tuyau	Rohr	
	12	35 10 34 70	Gommino antivibr.	Rubber block	Caoutchouc	Gummistück	
	13	95 10 11 40	Rosetta	Washer	Rondelle	Unterlegscheibe	
	14	95 00 02 06	Rosetta piana	Washer	Rondelle	Unterlegscheibe	
	15	98 05 23 30	Bullone	Bolt	Boulon	Bolzen	
	16	35 43 40 70	Molla	Spring	Ressort	Feder	
	17	98 05 44 25	Bullone	Bolt	Boulon	Bolzen	
	18	92 60 22 08	Dado	Nut	Ecrou	Mutter	
	19	35 43 21 70	Cavalletto laterale	Side stand	Etrier latérale	Seitenbock	
	20	35 67 70 00	Pedale com. freno	Brake pedal	Pédale comm. frein	Rückbremspedal	
	21	95 00 02 08	Rosetta piana	Washer	Rondelle	Unterlegscheibe	
	22	35 43 29 00	Molla	Spring	Ressort	Feder	
	23	35 67 65 70	Perno com. freno	Brake pin	Pivot comm. frein	Bremstift	
	24	35 44 02 70	Supp. pedana destra	Right foot rest supp.	Supp. repose-pieds dr.	R. Trittbrettunterstütz.	
	25	98 62 25 25	Vite	Screw	Vis	Schraube	
	26	35 44 07 50	Ped. appoggiapiedi ds.	Right foot rest	Repose-pieds droite	Rechts Trittbretter	
	27	98 05 24 30	Bullone	Bolt	Boulon	Bolzen	
	28	35 44 13 70	Supp. pedana sinistra	Left foot rest supp.	Supp. repose-pieds g.	L. Trittbrettunterstütz	
	29	35 44 18 50	Ped. appoggiapiedi sn.	Left foot rest	Repose-pieds gauche	Links Trittbretter	
	30	92 63 01 08	Dado autobloccante	Self-locking nut	Ecrou à autoblocage	Selbstklemmutter	
	31	98 05 24 80	Bullone	Bolt	Boulon	Bolzen	
	32	98 05 24 75	Bullone	Bolt	Boulon	Bolzen	
	33	35 42 89 70	Staffa sost. motore	Bracket	Etrier	Bügel	
	34	98 05 23 45	Bullone	Bolt	Boulon	Bolzen	
	35	61 01 38 00	Rosetta ondulata	Washer	Rondelle	Unterlegscheibe	
	36	92 60 22 06	Dado	Nut	Ecrou	Mutter	
	37	61 27 03 00	Rosetta ondulata	Washer	Rondelle	Unterlegscheibe	

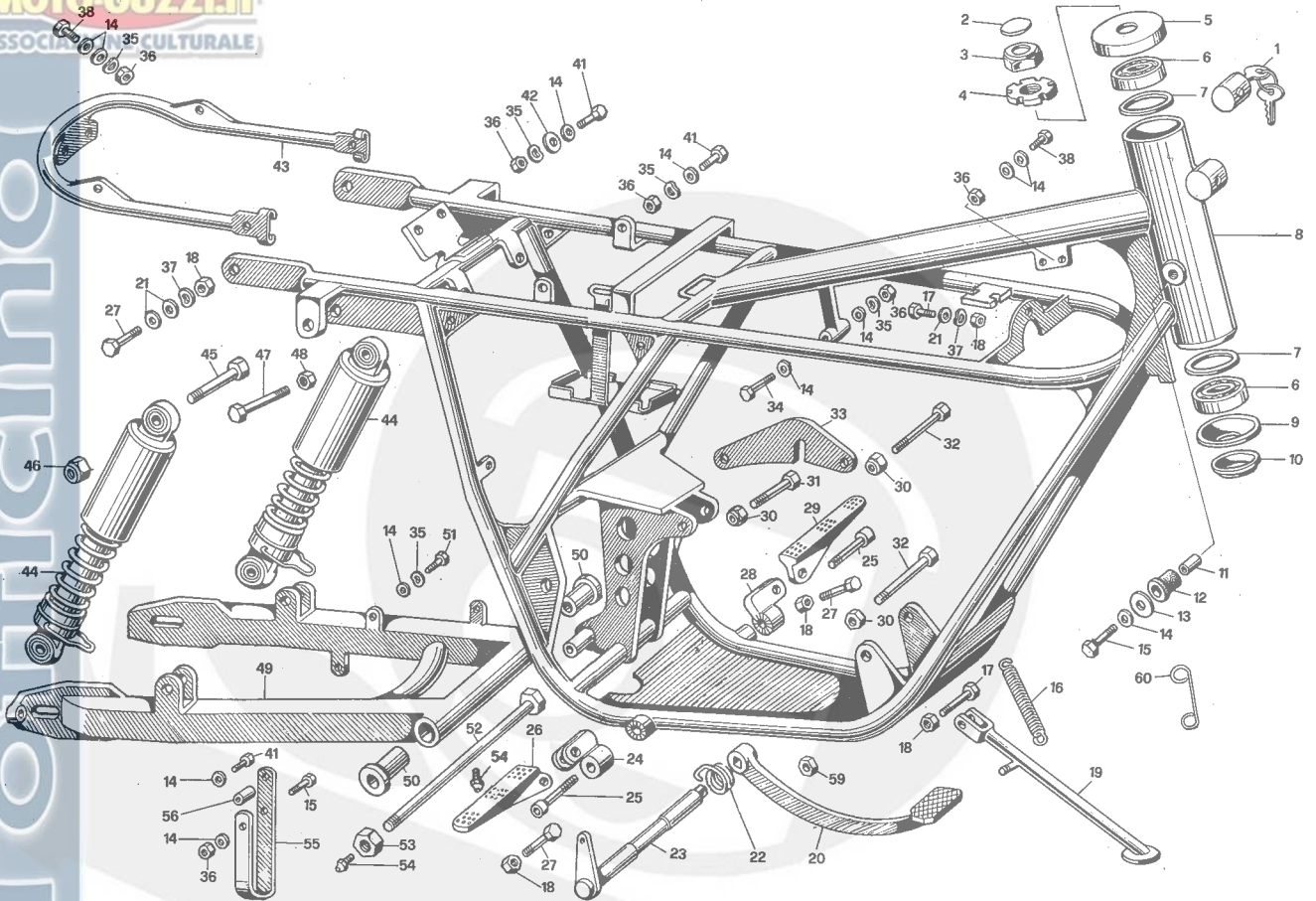

NOTE NOTES NOTES MARKE	POS. N.	N. COD. CODE No. CODE CODE Nr.	DENOMINAZIONE	DESCRIPTION	DESIGNATION	BEZEICHNUNG	N. DIS. DRWG. No. No. PLAN ZEICHN. Nr.
	38	98 05 43 16	Bullone	Bolt	Boulon	Bolzen	
	41	98 05 43 14	Bullone	Bolt	Boulon	Bolzen	
	42	95 10 01 18	Rosetta rinforzo	Washer	Rondelle	Unterlegscheibe	
	43	35 43 91 70	Cavalotto sost. paraf.	U - bolt	Etrier	Bügelsschraube	
	44	35 55 02 71	Ammortizzatore post.	Rear shock absorber	Amortisseur arrière	Hint. Stossdämpfer	
	45	98 05 25 50	Bullone	Bolt	Boulon	Bolzen	
	46	92 63 01 10	Dado autobloccante	Self-locking nut	Ecrou à autoblocage	Selbstklemmutter	
	47	98 05 25 40	Bullone	Bolt	Boulon	Bolzen	
	48	92 60 24 10	Dado	Nut	Ecrou	Mutter	
	49	35 54 02 70	Forcellone	Fork	Grande fourche	Gabel	
	50	35 54 71 70	Boccola	Bush	Douille	Buchse	
	51	98 05 43 12	Bullone	Bolt	Boulon	Bolzen	
	52	35 54 70 70	Perno forcellone	Fork pin	Pivot fourche	Gabelstift	
	53	35 54 78 70	Dado	Nut	Ecrou	Mutter	
	54	94 02 00 50	Ingrassatore	Grease nipple	Graisseur	Fettbüchse	
	55	35 55 96 50	Cruna catena	Chain bracket	Chas de chaîne	Kettenglied	
	56	35 55 97 50	Distanziale	Spacer	Entretoise	Abstandstück	
	59	92 60 25 10	Dado	Nut	Ecrou	Mutter	
	60	35 62 75 00	Occhiello rit. fili	Wire holder	Guide câble	Kabelhalter	

MOTO-GUZZI.IT
SOCIETA' COOPERATIVA

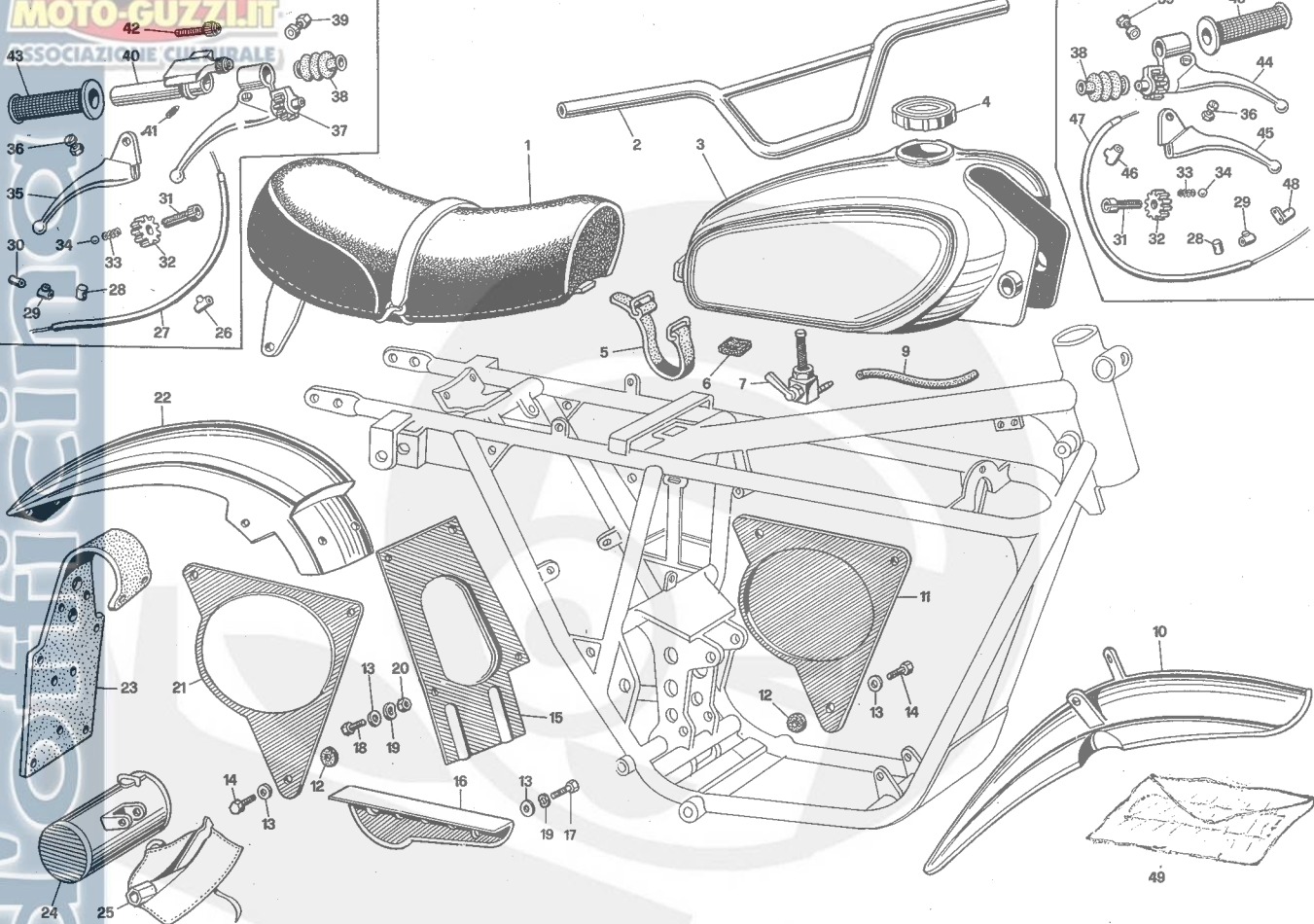

NOTE NOTES NOTES MARKE	POS. N.	N. COD. CODE No. No. CODE CODE Nr.	DENOMINAZIONE	DESCRIPTION	DESIGNATION	BEZEICHNUNG	N. DIS. DRWG. No. No. PLAN ZEICHN. Nr.
	1	35 46 05 70	Sella "Guzzi"	"Guzzi" saddle	Selle "Guzzi"	Sattel "Guzzi"	
	1	69 46 05 00	Sella "Benelli"	"Benelli" saddle	Selle "Benelli"	Sattel "Benelli"	
	2	35 60 03 70	Manubrio	Handle-bar	Guidon	Lenker	
	3	35 10 02 70	Serbatoio	Fuel tank	Réservoir	Kraftstoffbehälter	
	4	35 10 39 70	Tappo serbatoio	Fuel filler cap	Bouchon réservoir	Behälterverschluss	
	5	35 10 26 70	Fascetta serr. serb.	Clamp	Collier	Schelle	
	6	35 10 38 70	Feltro	Felt	Feutre	Filz	
	7	35 10 54 00	Rubinetto carburante	Fuel cock	Robinet carburant	Kraftstoffhahn	
	9	39 11 13 00	Tubazione carburante	Fuel pipe	Tuyau carburant	Kraftstoffrohr	
	10	35 43 43 70	Parafango anteriore	Front mudguard	Garde-boue AV	Vord. Kotflügel	
	11	35 78 43 70	Piastra portanum. sn.	Left racing number pl.	Plaque porte-n. gauche	Links Nummernplatte	
	12	93 11 01 22	Spessore elastico	Flex. spacer	Epaisseur élast.	El. Unterlage	
	13	95 00 02 06	Rosetta piana	Washer	Rondelle	Unterlegscheibe	
	14	98 05 43 12	Bullone	Bolt	Boulon	Bolzen	
	15	35 43 87 70	Paratia protezione	Battery plate	Cloison	Batterieschutz	
	16	35 47 30 70	Copricatena	Chain cover	Carter de chaîne	Kettenkasten	
	17	98 05 43 12	Bullone	Bolt	Boulon	Bolzen	
	18	98 05 43 14	Bullone	Bolt	Boulon	Bolzen	
	19	61 01 38 00	Rosetta ondulata	Washer	Rondelle	Unterlegscheibe	
	20	92 60 22 06	Dado	Nut	Ecrou	Mutter	
	21	35 78 42 70	Piastra portanum. ds.	Right racing num.-pl.	Plaque porte-n. droite	Rechts Nummernplatte	
	22	35 43 70 70	Parafango posteriore	Rear mudguard	Garde-boue AR	Hint. Kotflügel	
	23	35 47 50 70	Portatarga	Numberplate holder	Porte-plaque	Nummerschild Halter	
	24	35 47 60 50	Borsetta porta attrez.	Tool-kit bag	Sacoché d'outillage	Werkzeugtasche	
	25	35 92 99 70	Trousse completa	Tool-kit	Trousse comp. outils	Werkzeugset, kpl.	
	26	35 78 40 50	Ingrassatore	Grease nipple	Graisneur	Fettbüchse	
	27	35 62 54 70	Filo freno anter.	Front brake cable	Câble frein AV	Vord. Bremskabel	
	28	35 09 48 00	Barilotto per fili	Cable-end	Terminal du fil	Kabelende	
	29	48 80 24 70	Morsetto	Clamp	Borne	Bügel	
	30	35 09 37 70	Gommino terminale	Rubber block	Caoutchouc	Gummistück	
	31	35 60 24 70	Vite tendifilo	Screw	Vis	Schraube	
	32	35 60 25 70	Ghiera	Ring nut	Collier	Nutmutter	
	33	35 60 26 70	Molla	Spring	R ressort	Feder	
	34	92 29 57 04	Sfera	Ball	Bille	Kügel	
	35	35 60 56 70	Leva destra	Right lever	Levier droit	Rechts Hebel	
	36	35 60 52 70	Vite	Screw	Vis	Schraube	
	37	35 60 54 70	Supp. con leva destra	Supp. with right lever	Supp. avec lev. droit	Unterst. mit Rechts Hebel	

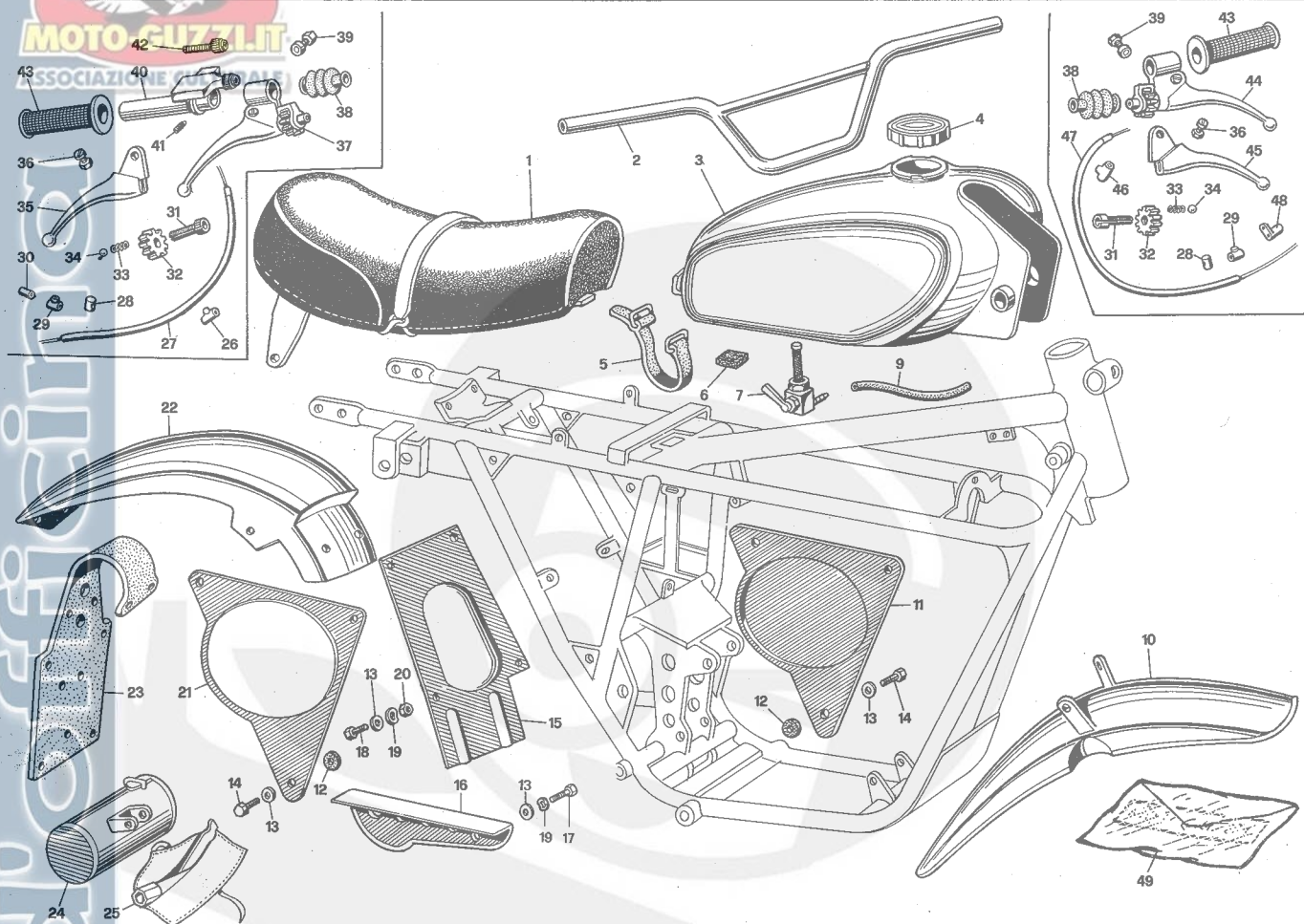

NOTE NOTES NOTES MARKE	POS. N.	N. COD. CODE No. No. CODE CODE Nr.	DENOMINAZIONE	DESCRIPTION	DESIGNATION	BEZEICHNUNG	N. DIS. DRWG. No. No. PLAN ZEICHN. Nr.
	38	35 09 38 70	Soffietto	Bellows	Soufflet	Balg	
	39	35 60 49 70	Vite	Screw	Vis	Schraube	
	40	35 60 34 00	Comando gas	Twist-grip	Commande des gaz	Gasdrehgriff	
	41	35 60 44 70	Grano fermo com.	Dowel	Grain	Feststellschraube	
	42	35 60 84 70	Vite tendifilo	Screw	Vis	Schraube	
	43	39 60 35 01	Manopola destra	Right hand grip	Poignée droite	Rechter Griff	
	43	39 60 30 01	Manopola sinistra	Left hand grip	Poignée gauche	Linker Griff	
	44	35 60 55 70	Supp. con leva sin.	Supp. with left lever	Supp. avec lev. gauche	Unter. mit Links Hebel	
	45	35 60 57 70	Leva sinistra	Left lever	Levier gauche	Links Hebel	
	46	35 78 40 70	Ingrassatore	Grasse nipple	Graisseur	Fettbüchse	
	47	35 09 30 70	Filo frizione	Clutch cable	Fil embrayage	Kupplungsdraht	
	48	35 09 37 00	Gommino terminale	Rubber block	Caoutchouc	Gummistück	
	49	35 91 73 00	Decalcoman. serbatoio "Guzzi"	"Guzzi" tank transfer	Décalcom. réservoir "Guzzi"	Behälterabziehbild "Guzzi"	
	49	71 92 20 00	Decalcoman. serbatoio "Benelli"	"Benelli" tank transfer	Décalcom. réservoir "Benelli"	Behälterabziehbild "Benelli"	

Manuali

FORCELLA ANTERIORE
FRONT FORK
FOURCHE AVANTE
VORDERE GABEL

125 TRIAL (045.00)

Tavola - Drawing
 Table - Bild

6

MOTO-GUZZI
 ASSOCIAZIONE CULTURALE

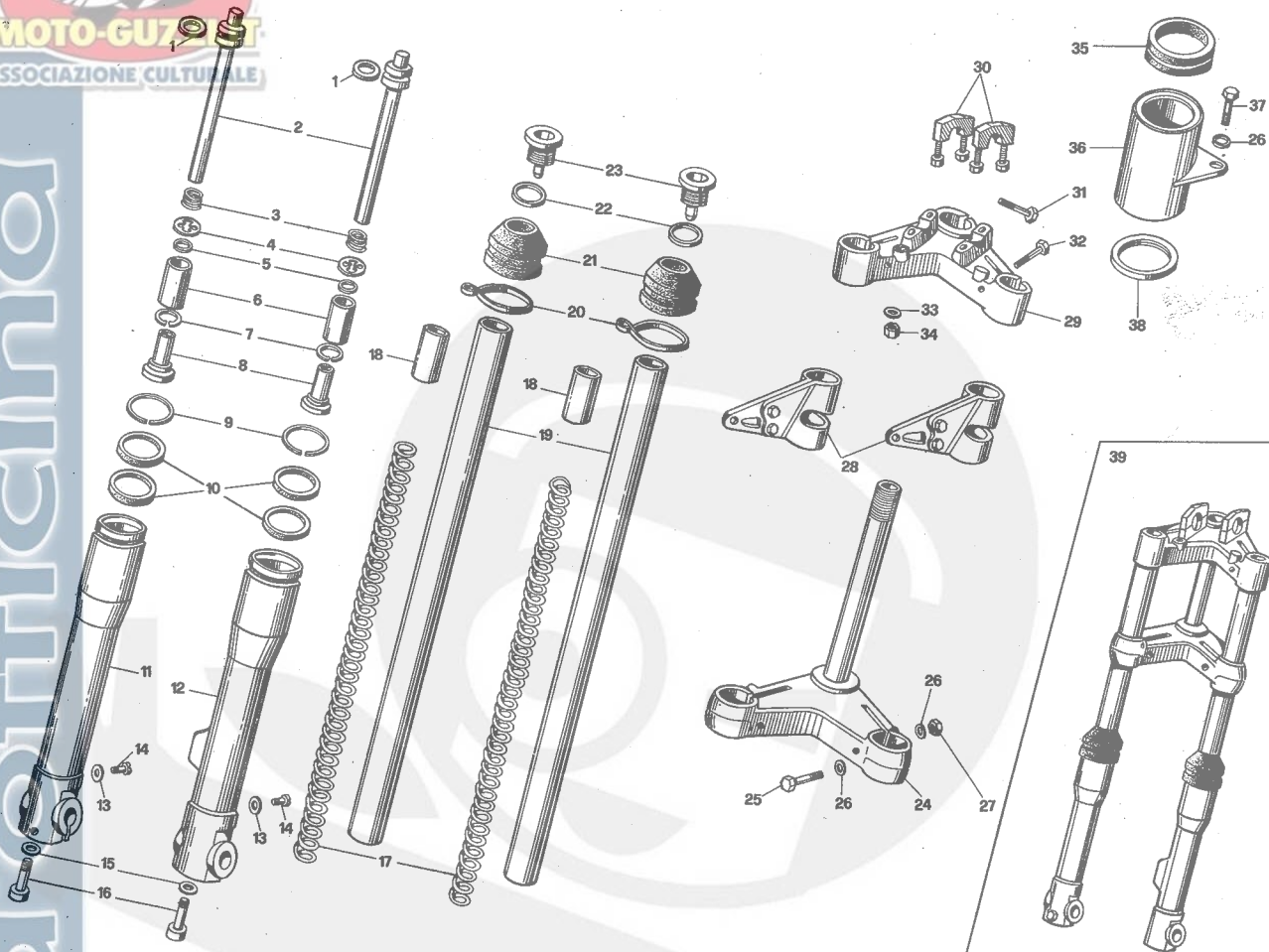

NOTE NOTES NOTES MARKE	POS. N.	N. COD. CODE No. No. CODE CODE Nr.	DENOMINAZIONE	DESCRIPTION	DESIGNATION	BEZEICHNUNG	N. DIS. DRWG. No. No. PLAN ZEICHN. Nr.
	1	39 52 58 00	Segmento in nylon	Nylon ring	Segment en nylon	Nylonsegment	
	2	39 52 55 00	Asta freno idraulico	Hydraulic brake rod	Tige du frein hydr.	Bremsestange.	
	3	39 52 88 00	Contromolla	Return-spring	Contre-ressort	Gegenfeder	
	4	39 52 62 00	Rosetta	Washer	Rondelle	Unterlegscheibe	
	5	39 52 82 00	Valvola	Valve	Soupape	Ventil	
	6	39 52 81 00	Bussola	Bush	Douille	Buchse	
	7	39 52 61 00	Anello di sicurezza	Circlip	Bague d'arrêté	Sicherheitsring	
	8	39 52 78 00	Bussola fondo gamba	Bush	Douille	Buchse	
	9	90 27 30 44	Anello di sicurezza	Circlip	Bague d'arrêté	Sicherheitsring	
	10	90 40 32 41	Anello di tenuta	Seal ring	Bague d'étanchéité	Dichtring	
	11	35 52 25 70	Gambale destro	Right leg	Montant droit	Rechts Bein	
	12	35 52 26 70	Gambale sinistro	Left leg	Montant gauche	Links Bein	
	13	90 71 40 62	Guarnizione	Gasket	Joint	Dichtung	
	14	98 30 60 04	Vite	Screw	Vis	Schraube	
	15	39 52 37 00	Guarnizione	Gasket	Joint	Dichtung	
	16	98 62 25 25	Vite	Screw	Vis	Schraube	
	17	39 52 66 00	Molla	Spring	Ressort	Feder	
	18	35 52 77 70	Tubetto precarica	Pre-load tube	Tuayu pré-charge	Vorspannungsrohr	
	19	35 52 54 70	Canna portante	Bearing rod	Cadre portant	Mittragendes Rohr	
	20	39 52 84 00	Anello passafilo	Ring	Bague	Ring	
	21	35 52 45 00	Raschiapolvere	Dust scraper	Racle poussière	Staubstreif	
	22	39 50 46 00	Anello di tenuta	Seal ring	Bague d'étanchéité	Dichtring	
	23	39 50 45 00	Tappo superiore	Upper plug	Bouchon supérieur	Ob. Stöpsel	
	24	35 49 40 70	Base di sterzo	Steering base	Socle de direction	Lenkerbasis	
	25	98 05 24 60	Bullone	Bolt	Boulon	Bolzen	
	26	95 00 02 08	Rosetta piana	Washer	Rondelle	Unterlegscheibe	
	27	92 60 22 08	Dado	Nut	Ecrou	Mutter	
	28	35 49 67 70	Sostegno fanale	Lamp support	Support feu.	Schlusslampeunterst.	
	29	35 49 31 70	Testa di sterzo	Steering head	Tête de la col. de direc.	Lenkerkopf	
	30	35 50 05 00	Cavallotto fiss. man.	Stand	Etrier	Bock	
	31	98 62 24 30	Vite	Screw	Vis	Schraube	
	32	98 62 04 40	Vite	Screw	Vis	Schraube	
	33	95 00 02 06	Rosetta piana	Washer	Rondelle	Unterlegscheibe	
	34	35 50 03 00	Dado	Nut	Ecrou	Mutter	
	35	35 76 23 70	Guarnizione	Gasket	Joint	Dichtung	
	36	35 50 15 70	Supporto contachilom.	K. - support	Support compte-km	Km. Unterst.	
	37	98 05 44 20	Bullone	Bolt	Boulon	Bolzen	
	38	35 50 39 70	Anello blocc. contakm.	Speedom. ring	Bague compt. kilom.	Tachom. Ring	
	39	35 49 02 70	Forcella anter. compl.	Front fork, compl.	Fourche AV, compl.	Vord. Gabel, kpl.	

Dati indicativi soggetti a modifiche senza impegno di preavviso - Les données sont sujettes à modifications sans préavis Printed in Italy

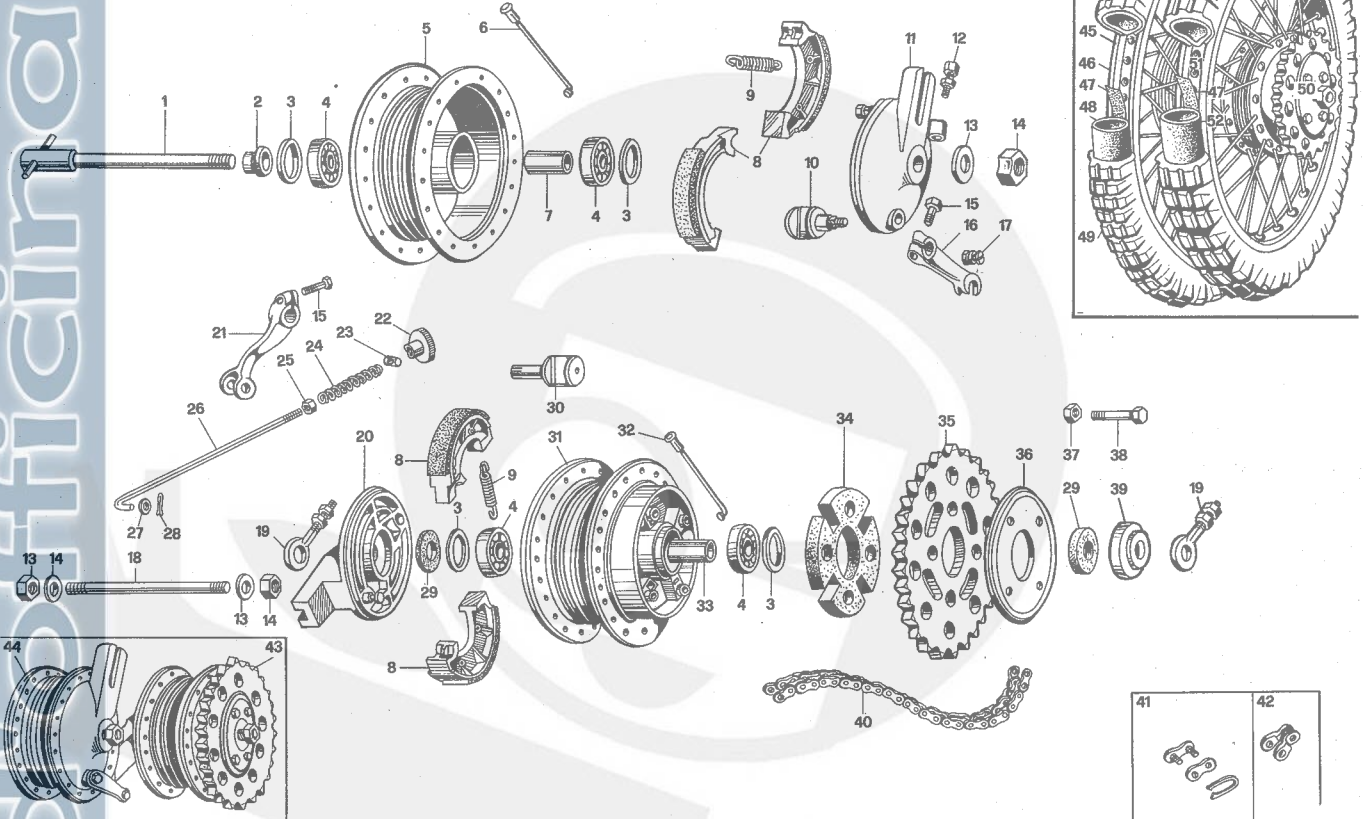

NOTE NOTES NOTES MARKE	POS. N.	N. COD. CODE No. No. CODE CODE Nr.	DENOMINAZIONE	DESCRIPTION	DESIGNATION	BEZEICHNUNG	N. DIS. DRWG. No. No. PLAN ZEICHN. Nr.
	1	35 61 41 70	Perno ruota	Wheel spindle	Pivot roue	Radstift	
	2	35 61 56 70	Distanziale	Spacer	Entretoise	Distanzstück	
	3	39 61 47 00	Copripolvere	Dust guard	Pare-poussière	Staubkappe	
	4	92 20 12 15	Cuscinetto	Bearing	Roulement	Kugellager	
	5	35 61 32 70	Corpo mozzo anter.	Front hub body	Corps moyeu AV	Vord. Nabe	
	6	35 61 15 70	Raggio ruota anter.	Front wheel spokes	Rayons roue AV	Vord. Radspeiche	
	7	35 61 52 70	Distanziale	Spacer	Entretoise	Distanzstück	
	8	35 62 08 00	Ceppi freno	Brake shoe	Mâchoires du frein	Bremsklotz	
	9	35 62 21 00	Molla	Spring	Ressort	Feder	
	10	61 63 25 00	Camma	Cam	Came	Daumenscheibe	
	11	35 62 02 70	Piatto	Plate	Plaque	Platte	
	12	35 62 69 70	Registrafilo	Wire adjuster	Réglage des fils	Kabeleinstellschraube	
	13	39 61 22 00	Rosetta	Washer	Rondelle	Unterlegscheibe	
	14	39 61 21 00	Dado	Nut	Ecrou	Mutter	
	15	98 05 43 22	Bullone	Bolt	Boulon	Bolzen	
	16	35 62 50 00	Leva freno anter.	Front brake lever	Levier frein AV	Vord. Bremshebel	
	17	48 80 24 70	Morsetto	Clamp	Borne	Bügel	
	18	35 63 33 70	Perno ruota	Wheel spindle	Pivot roue	Radstift	
	19	35 33 63 70	Tendicatena	Chain stretcher	Tendeur de chaîne	Kettenspanner	
	20	35 63 52 70	Piatto	Plate	Plaque	Platte	
	21	39 63 96 00	Leva freno post.	Rear brake lever	Levier frein AR	Hint. Bremshebel	
	22	39 67 62 00	Dado registro freno	Brake nut	Ecrou reg. frein	Bremsmutter	
	23	39 67 63 00	Barilotto freno post.	Rear brake cable-end	Terminal du fil frein ar.	Hint. Bremskabelende	
	24	39 67 64 00	Molla	Spring	Ressort	Feder	
	25	92 60 22 06	Dado	Nut	Ecrou	Mutter	
	26	35 67 60 70	Asta freno poster.	Rear brake rod	Tige frein AR	Hint. Bremstange	
	27	95 00 02 06	Rosetta piana	Washer	Rondelle	Unterlegscheibe	
	28	95 40 12 15	Copiglia	Cotter pin	Goupille	Splint	
	29	39 61 70 00	Feltro	Felt	Feutre	Filz	
	30	35 63 25 70	Camma	Cam	Came	Daumenscheibe	
	31	35 63 31 70	Corpo mozzo post.	Rear hub body	Corps moyeu AR	Hint. Nabe	
	32	35 61 15 00	Raggio ruota post.	Rear wheel spokes	Rayons roue AR	Hint. Radspeiche	
	33	35 63 40 70	Distanziale	Spacer	Entretoise	Distanzstück	
	34	35 33 69 70	Parastrappi	Flexible coupling	Accoup. extensible	Elastische Kupplung	
	35	35 33 37 70	Corona posteriore	Rear crown	Couronne AR	Hinterekranz	
	36	35 63 24 70	Piatto parastrappi	Flex. coupl.plate	Plaque accoup. ext.	El. Kuppl. Platte	

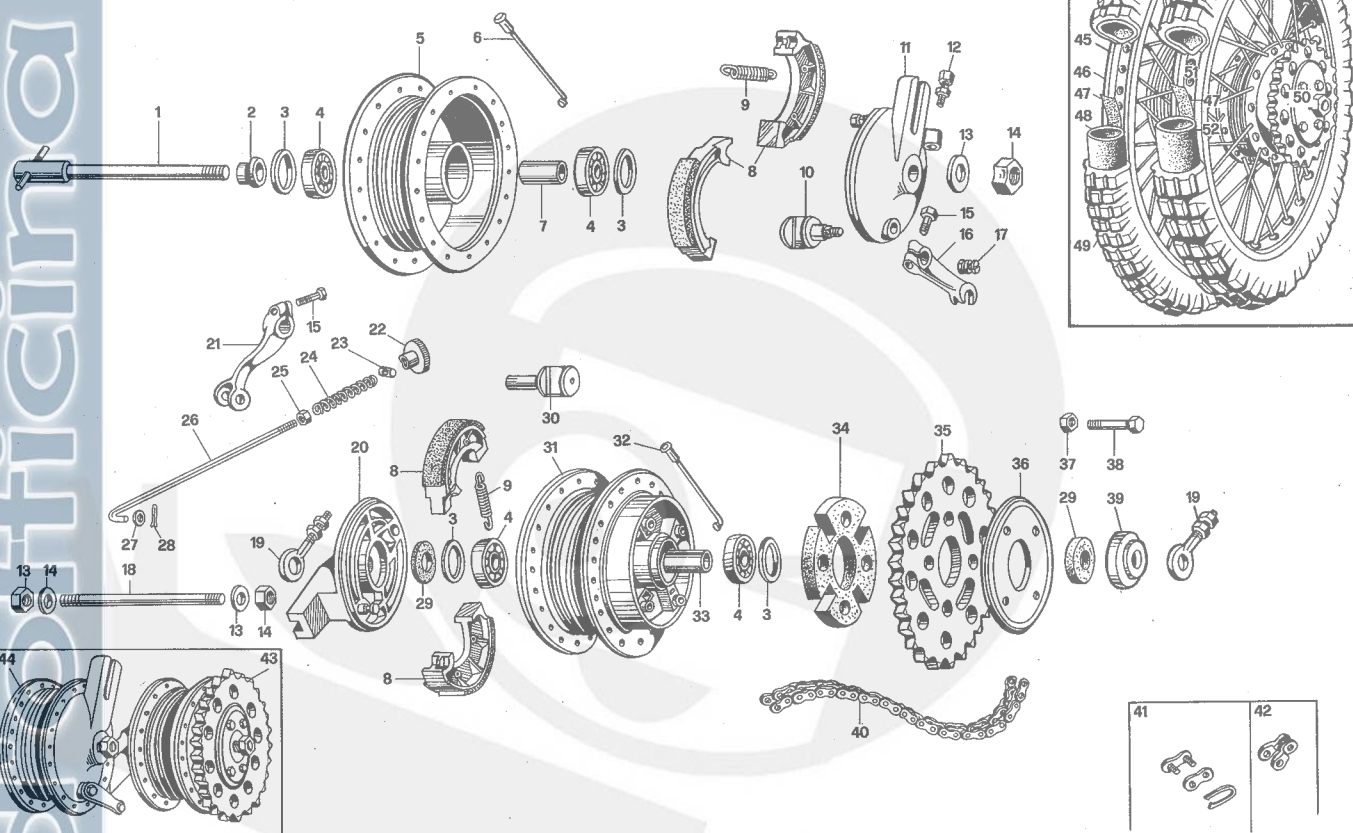

NOTE NOTES NOTES MARKE	POS. N.	N. COD. CODE No. No. CODE CODE Nr.	DENOMINAZIONE	DESCRIPTION	DESIGNATION	BEZEICHNUNG	N. DIS. DRWG. No. No. PLAN ZEICHN. Nr.
---------------------------------	------------	---	---------------	-------------	-------------	-------------	---

	37	92 70 10 72	Dado	Nut	Ecrou	Mutter	
	38	35 33 49 70	Bullone	Bolt	Boulon	Bolzen	
	39	35 63 41 70	Distanziale	Spacer	Entretoise	Distanzstück	
	40	35 33 22 70	Catena	Chain	Chaîne	Kette	
	41	35 33 31 70	Maglia	Link	Maillon	Glied	
	42	35 33 34 70	Falsa maglia	Dummy link	Faux maillon	Falsches Glied	
	43	35 63 29 70	Mozzo ruota post.	Rear wheel hub	Moyeu roue AR	Hint. Radnabe	
	44	35 61 29 70	Mozzo ruota ant.	Front wheel hub	Moyeu roue AV	Vord. Radnabe	
	45	35 61 02 70	Ruota ant. completa	Front wheel, compl.	Roue AV, compl.	Vorderrad, kpl.	
	46	35 61 08 70	Cerchio ruota anter.	Front wheel rim	Jante roue AV	Vord. Radfelge	
	47	35 61 78 00	Nastro paraniplis	Nipples band	Ruban pare-nipples	Nippel-Schutzband	
	48		Camera d'aria	Air tube	Chambre à air	Luftreifen	
	49		Copertura anter.	Front tyre	Pneu roue AV	Vord. Rádfelge	
	50	35 63 02 70	Ruota post. completa	Rear wheel, compl.	Roue AR, compl.	Hinterrad, kpl.	
	51	35 63 07 70	Cerchio ruota post.	Rear wheel rim	Jante roue AR	Hint. Radfelge	
	52		Camera d'aria	Air tube	Chambre à air	Luftreifen	
	53		Copertura post.	Rear tyre	Pneu roue AR	Hint. Radfelge	

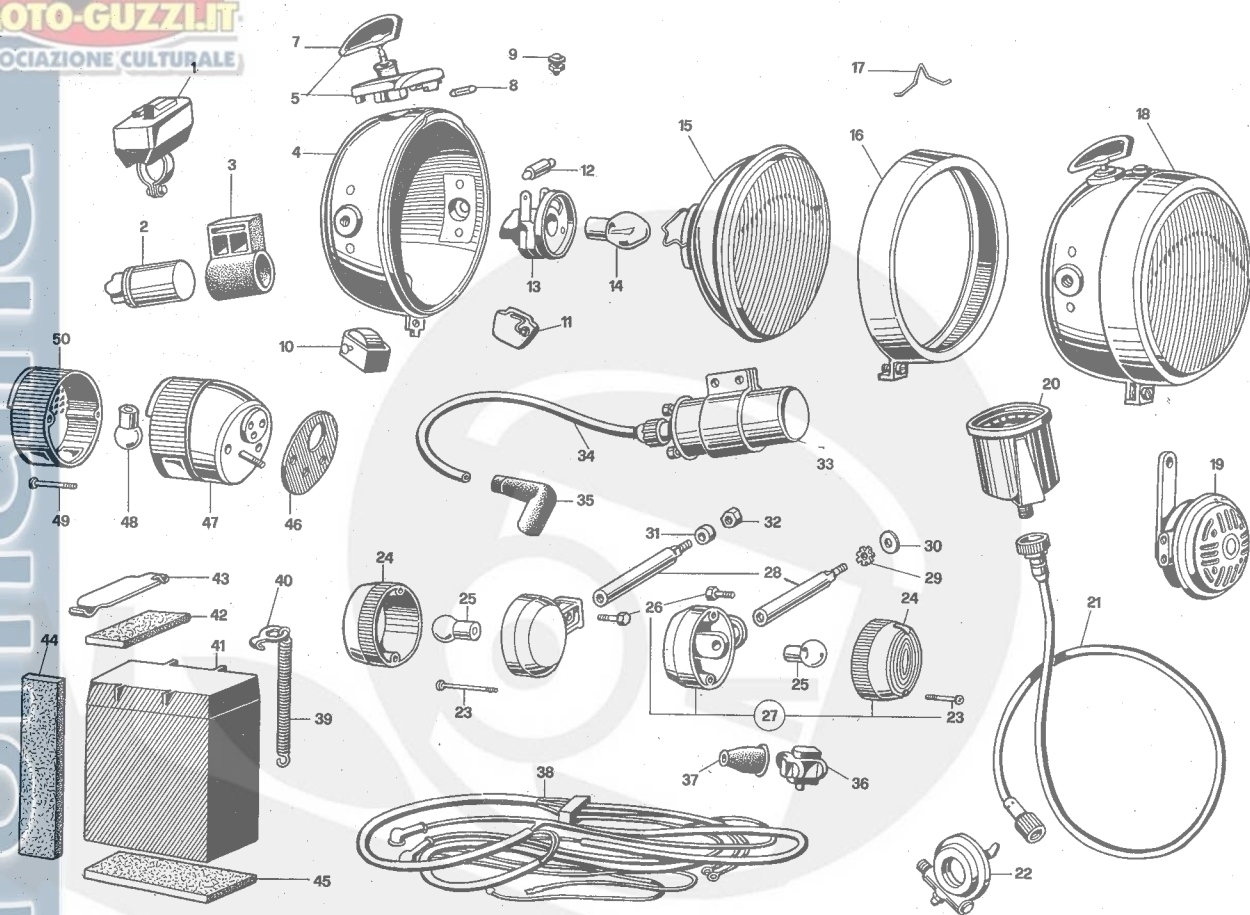

NOTE NOTES NOTES MARKE	POS. N.	N. COD. CODE No. No. CODE CODE Nr.	DENOMINAZIONE	DESCRIPTION	DESIGNATION	BEZEICHNUNG	N. DIS. DRWG. No. No. PLAN ZEICHN. Nr.
	1	35 74 60 70	Dispositivo	Device	Dispositif	Vorrichtung	
	2	35 75 05 70	Intermittenza	Device	Intermittence	Aussetzung	
	3	17 75 12 00	Sostegno elastico	Flexible support	Support élastique	Elast. Stütze	
	4	35 74 04 70	Calotta	Steering upper cov.	Calotte	Lenkerkalotte	
	5	35 74 04 71	Pannello commutatore	Switch panel	Panneau commutateur	Schalttafel	
	7	35 74 04 73	Chiave accensione	Ignition key	Clé de contact	Zundschlüssel	
	8	55 74 25 26	Fusibile	Fuse	Fusible	Sicherung	
	9	35 75 48 70	Spia completa	Warning light	Témoin complet	Kontrolllampe, kpl.	
	10	35 74 04 75	Impedenza	Impedance	Résistance	Scheinwiderstand	
	11	35 74 04 76	Raddrizzatore	Rectifier	Redresseur	Gleichrichter	
	12	93 45 03 12	Lampada	Lamp	Lampe	Lampe	
	13	35 74 04 77	Portalamпада	Lamp holder	Douille	Lampefassung	
	14	93 45 02 14	Lampada biluce	Twin fil. lamp	Ampoule à deux feux	Bilux Lampe	
	15	35 74 04 78	Proiettore parabolico	Parabolic reflector	Projecteur parabolique	Parabolreflektor	
	16	35 74 04 79	Ghiera	Ring nut	Collier	Nutmutter	
	17	39 74 05 30	Molla	Spring	Ressort	Feder	
	18	35 74 05 70	Proiettore	Headlight	Phare	Scheinwerfer	
	19	35 74 37 70	Avvisatore acustico	Warning horn	Avertisseur acoustique	Hupe	
	20	35 76 15 70	Orologio contachilom.	Speedometer	Compteur kilom.	Kilometerzähler	
	21	35 76 04 70	Trasmissione	Cable	Câble	Zählerkabel	
	22	35 76 25 70	Rinvio contachilom.	Driving gear	Renvoi compteur kil.	Vorgelege km-Zähler	
	23	35 75 18 70	Vite	Screw	Vis	Schraube	
	24	35 75 19 70	Catadiottro	Reflector	Catadioptré	Rückstrahler	
	25	93 45 04 12	Lampada	Lamp	Lampe	Lampe	
	26	98 05 42 14	Bullone	Bolt	Boulon	Bolzen	
	27	35 75 37 70	Indicatore completo	Blinking, compl.	Clignotant complet	Blinklicht, kpl.	
	28	35 75 13 70	Attacco	Coupling	Support	Verbindung	
	29	95 02 11 08	Rosetta dentellata	Washer	Rondelle	Unterlegscheibe	
	30	95 00 02 08	Rosetta piana	Washer	Rondelle	Unterlegscheibe	
	31	35 75 34 70	Distanziale	Spacer	Entretoise	Distanzstück	
	32	92 60 24 08	Dado	Nut	Ecrou	Mutter	
	33	35 71 65 00	Bobina A.T.	H.T. coil	Bobine H.T.	H.S. Spule	
	34	39 71 73 00	Cavo candela	Spark plug cable	Câble bougie	Kerzenkabel	
	35	39 71 74 00	Presca di corrente	Socket	Prise courant	Kerzenstecker	
	35	35 71 74 70	Pr. corr. Vers. Francia	France Vers. socket	Pr. cour. Vers. France	Kerzenst., Frankreichversion	
	36	35 74 11 70	Interruttore stop	Stop switch	Interrupteur stop	Halteschalter	

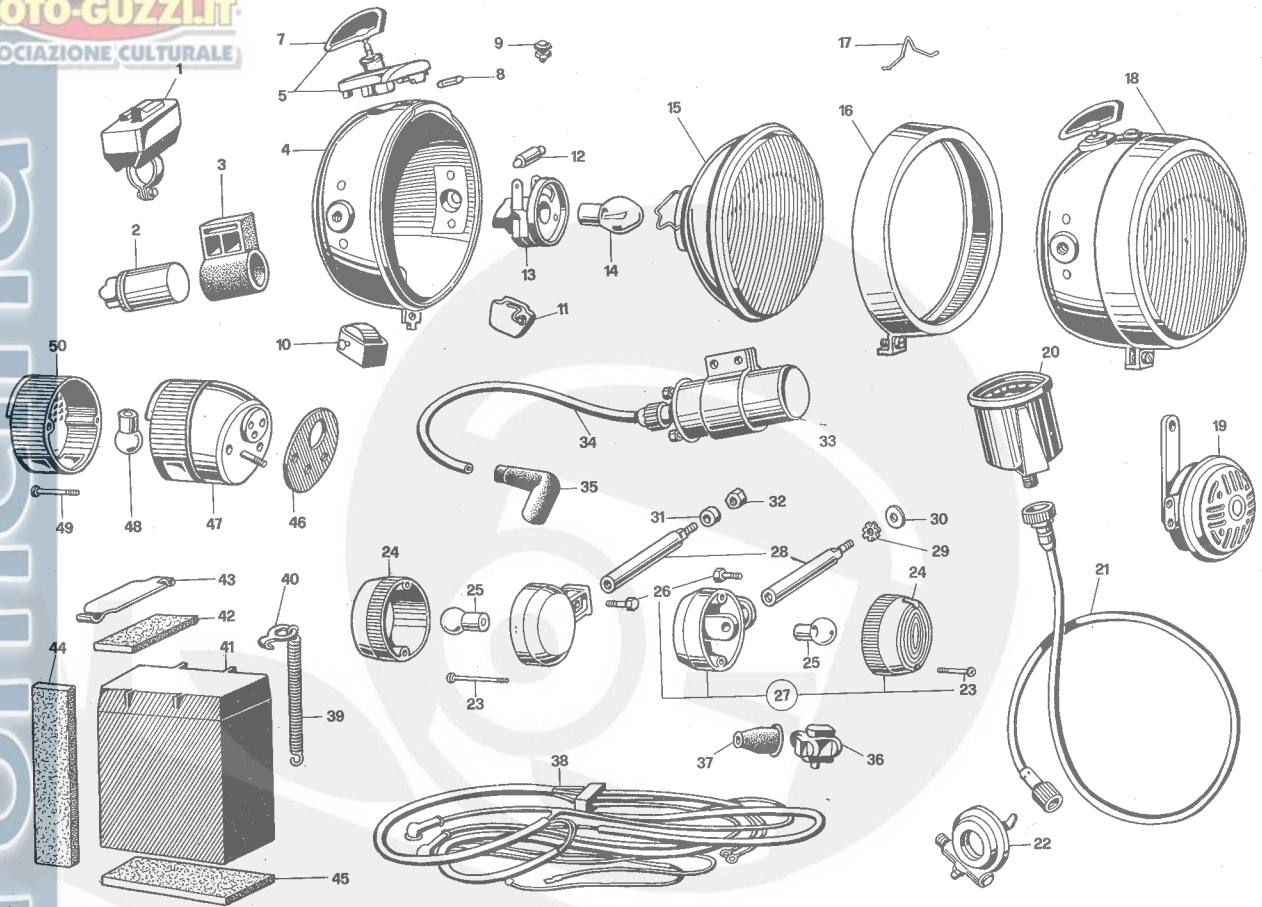
MOTO-GUZZI.IT
 ASSOCIAZIONE CULTURALE

NOTE NOTES NOTES MARKE	POS. N.	N. COD. CODE No. No. CODE CODE Nr.	DENOMINAZIONE	DESCRIPTION	DESIGNATION	BEZEICHNUNG	N. DIS. DRWG. No. No. PLAN ZEICHN. Nr.
	37	35 75 53 70	Cappuccio	Cap	Capuchon	Deckel	
	38	35 74 71 70	Impianto fili	Wire system	Installation des fils	Kabelanlage	
	39	39 70 55 00	Molla	Spring	Ressort	Feder	
	40	39 70 58 00	Piastrino	Plate	Plaque	Platte	
	41	39 70 45 00	Batteria	Battery	Batterie	Batterie	
	42	39 70 57 00	Feltro	Felt	Feutre	Filz	
	43	39 70 53 00	Piastrino	Plate	Plaque	Platte	
	44	39 70 59 00	Feltro	Felt	Feutre	Filz	
	45	39 70 56 00	Feltro	Felt	Feutre	Filz	
	46	35 74 59 70	Rinforzo	Reinforcement	Renfort	Verstärkung	
	47	35 74 09 70	Fanalino posteriore	Tail light	Feu AR	Rücklicht	
	48	93 45 02 13	Lampada	Lamp	Lampe	Lampe	
	49	35 74 17 71	Vite	Screw	Vis	Schraube	
	50	35 74 17 70	Catadiottro	Reflector	Catadioptré	Rückstrahler	